

National Aeronautics and Space Administration

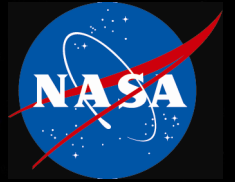

# Mission Concept Study

## Planetary Science Decadal Survey MSR Orbiter Mission (Including Mars Returned Sample Handling)

Science Champion: Phil Christensen ([phil.christensen@asu.edu](mailto:phil.christensen@asu.edu))

NASA HQ POC: Lisa May ([lisa.may@nasa.gov](mailto:lisa.may@nasa.gov))

[www.nasa.gov](http://www.nasa.gov)

March 2010

# Data Release, Distribution, and Cost Interpretation Statements

This document is intended to support the SS2012 Planetary Science Decadal Survey.

The data contained in this document may not be modified in any way.

Cost estimates described or summarized in this document were generated as part of a preliminary concept study, are model-based, assume a JPL in-house build, and do not constitute a commitment on the part of JPL or Caltech. References to work months, work years, or FTEs generally combine multiple staff grades and experience levels.

Cost reserves for development and operations were included as prescribed by the NASA ground rules for the Planetary Science Decadal Survey. Unadjusted estimate totals and cost reserve allocations would be revised as needed in future more-detailed studies as appropriate for the specific cost-risks for a given mission concept.

# Planetary Science Decadal Survey

## Mission Concept Study Final Report

<b>Acknowledgments</b> .....	<b>iv</b>
<b>Executive Summary</b> .....	<b>v</b>
Mission Concept .....	v
Key Technologies and Risks.....	v
<b>1. Scientific Objectives</b> .....	<b>1</b>
Science Questions and Objectives .....	1
Science Traceability.....	1
<b>2. High-Level Mission Concept</b> .....	<b>2</b>
Overview .....	2
Concept Maturity Level .....	2
Technology Maturity.....	3
Key Trades.....	3
<b>3. Technical Overview</b> .....	<b>4</b>
Instrument Payload Description .....	4
Flight System .....	4
Concept of Operations and Mission Design.....	10
Planetary Protection.....	13
Risk List .....	13
<b>4. Development Schedule and Schedule Constraints</b> .....	<b>16</b>
High-Level Mission Schedule.....	16
Technology Development Plan .....	17
Development Schedule and Constraints.....	18
<b>5. Mission Life-Cycle Cost</b> .....	<b>19</b>
Costing Methodology and Basis of Estimate .....	19
Cost Estimates.....	19

## Figures

Figure 3-1 Preliminary Orbiter Configuration .....	5
Figure 3-2. Rendezvous and Capture System Designs.....	7
Figure 3-3. Earth Entry Vehicle Preliminary Design .....	8
Figure 3-4. Mars Returned Sample Handling Concept.....	10
Figure 3-5. Generic Mission Timeline .....	12
Figure 3-6. 5 x 5 Risk Matrix .....	14
Figure 4-1. Development Schedule for the Proposed Orbiter Mission and MRSH.....	16

## Tables

Table 2-1. Concept Maturity Level Definitions .....	3
Table 3-1. Orbiter Bus Mass and Power Estimates .....	5
Table 3-2. Preliminary Orbiter Characteristics .....	6
Table 3-3. Earth Entry Vehicle Mass and Power Estimate .....	9
Table 3-4. Mission Design Concept .....	11
Table 3-5. Comparative Mission Parameters .....	11
Table 3-6. Mission Operations and Ground Data Systems .....	12
Table 3-7. Top Risks for the Proposed Orbiter Mission and MRSH .....	14
Table 3-8. Risk Level Definitions .....	15
Table 4-1. Proposed Key Phase Duration .....	16
Table 5-1. Total Estimated Mission Cost Funding Profile .....	20

## Appendices

- A. Acronyms
- B. References
- C. Orbiter Master Equipment List from Team X Study
- D. Sample Receiving Facility Planning Article

# Acknowledgments

This report was authored by Richard Mattingly, Jet Propulsion Laboratory, California Institute of Technology.

This research was carried out at the Jet Propulsion Laboratory, California Institute of Technology, under a contract with the National Aeronautics and Space Administration.

© 2010. All rights reserved.

# Executive Summary

The Mars Sample Return (MSR) concept is a campaign of three missions: a sample acquisition/caching rover mission, a lander mission to fetch the cache and deliver it to Mars orbit via a rocket, and an orbiter that would capture the orbiting sample (OS) container and deliver it to Earth via an Earth entry vehicle (EEV). A fourth component is the Mars Returned Sample Handling (MRS) element that would include a sample receiving facility (SRF) and a curation facility. These elements are represented in three separate mission concept study reports:

- Mars 2018 MAX-C Caching Rover [1]
- MSR Lander Mission [2]
- MSR Orbiter Mission (including MRS)

The latter concept is the subject of this report.

The overall objective of the proposed MSR campaign would be to collect samples of Mars (mainly rock cores) and return them to Earth for in-depth analysis in terrestrial laboratories. The objective of the Orbiter Mission would be to rendezvous with and capture an OS container that would have been deposited into a 500 km circular orbit by the MSR Lander Mission and land the samples on Earth via an EEV. The MRS project objective would be to contain the EEV, transport it to an SRF for quarantine, apply a test protocol to assess potential hazards of the samples, and curate the samples for further distribution. The Orbiter Mission and MRS project must meet the planetary protection requirements of a restricted Earth-return mission.

While the MSR campaign might be an international endeavor, this report assumes that the Orbiter Mission would be performed by NASA and that the samples would be returned, contained, and assessed in the continental United States.

## Mission Concept

The orbiter would be launched on a medium-class vehicle on a trajectory that would reach Mars in ~9 months, and would aerobrake to a 500 km circular orbit over 6–9 months. Current plans have the orbiter arriving at Mars ~2 years before the MSR lander; it then could perform critical event coverage as well as telecom relay for the lander and its fetch rover. After ~6 months, the Mars ascent vehicle (MAV) would place the OS in a 500 km circular orbit comparable to the orbiter orbit. The orbiter would detect and track the OS, while maneuvering to rendezvous. The OS would be captured by the orbiter, sealed, and placed in an EEV. The orbiter would leave Mars on a non-impact trajectory to Earth, and shortly before arrival, target Earth, release the EEV, then divert away from Earth. The EEV would enter and hard land at a recovery site to be determined (baselined to be the Utah Test and Training Range [UTTR], decision pending the National Environmental Policy Act [NEPA] process and agreement with the U.S. Air Force).

The MRS element would then be responsible for safe transport of the EEV to an SRF, where the hardware and samples would remain in quarantine until determined to be safe by applying a testing protocol. If safe, the samples would be released to a curation facility for safe keeping and distribution to scientists and laboratories worldwide. While they are not costed in this study, options for conducting science in the SRF are being considered in the event the samples are not deemed safe to release.

## Key Technologies and Risks

The MSR Orbiter Mission concept uses the heritage and experience from a decade of orbiters at Mars. Rendezvous and capture at Mars is new, but concerns are mitigated by the experience of the Defense Advanced Research Projects Agency (DARPA) Orbital Express mission, which performed detection and rendezvous in Earth orbit under very similar conditions, and demonstration of an MSR capture basket concept on a zero-g aircraft campaign. Early development and testing of the EEV concept has taken the design far enough to mitigate concerns. The biggest challenge ahead is meeting the planetary protection requirements for a restricted Earth-return mission (termed back planetary protection [BPP]). A

probabilistic risk assessment (PRA) has indicated where technology developments are needed, some of which are reflected in the EEV concept. While basic techniques have been demonstrated in labs, components for sealing, leak detection, and dust mitigation still need to be brought up to technology readiness level (TRL) 6. The biggest development risk to the project is demonstrating that it can meet the BPP requirements.

# 1. Scientific Objectives

## Science Questions and Objectives

The Orbiter Mission is part of the Mars Sample Return (MSR) campaign concept, which would provide the transportation of a prepackaged and sealed cache of samples back to Earth. The proposed science objectives are described in the MAX-C and MSR lander mission concept studies [1, 2]. Two mission considerations relate to science integrity:

1. The sample cache should be kept below 20°C, except for a short period of time (one hour) after landing, where it could be allowed to rise to 50°C, with a goal of maintaining 20°C. This would be obtained passively both on the orbiter and the Earth entry vehicle (EEV). During free-flight, the orbiting sample (OS) container would always be around -50°C, so there would be no need to quickly capture it. Upon returning to Earth's surface, the temperature rise would be the worst case due to heat soak-back from entry and the more significant ambient input of sitting in the sun. Reaching the EEV and putting it into a cooled vault within approximately one hour would mitigate the temperature rise and would also be desirable for planetary protection.
2. Upon landing, shock should be kept to within 2,500 g's. The samples would be constrained inside sample tubes to maintain sample stratification. Drop tests of the EEV test models at the proposed (decision pending) landing site, Utah Training and Test Range (UTTR), have demonstrated that the EEV energy-absorbing impact materials can meet this need.

The Mars Returned Sample Handling (MRSB) element would have to ensure the same level of temperature control for the samples. Moreover, the samples would have to be kept isolated from terrestrial contaminants and each other. Standard methods of curation and clean handling common to semi-conductor, medical industries, and astromaterials curation/analysis would be applied.

## Science Traceability

The science traceability matrix is not included in this report because there is no science planned for the Orbiter Mission.



## 2. High-Level Mission Concept

### Overview

The Orbiter Mission is one of three missions comprising the proposed MSR campaign. Samples would be collected and cached by the first mission, MAX-C, preliminarily planned for a 2018 launch. A sample cache (two canisters for redundancy) would be left on the surface of Mars for possible later retrieval. The orbiter would be launched nominally in 2022 on a medium-class vehicle reaching Mars in ~9 months. The orbiter would insert into a highly elliptical orbit and aerobrake down to a 500 km circular orbit over 6–9 months. The third mission of the proposed MSR campaign, the lander, would nominally be launched in 2024, which would be the next opportunity to get to Mars. The orbiter would provide critical event coverage of the lander entry/descent/landing (EDL), and provide telecom relay for the proposed lander and its fetch rover dispatched to retrieve the sample cache. Approximately 6 months after lander arrival, the OS container would be launched by a Mars ascent vehicle (MAV) and the OS would be released in a 500 km orbit comparable with the orbiter. This is all part of the Lander Mission concept. The orbiter would provide critical event coverage of the MAV ascent and OS release and capture.

Using an optical camera, the orbiter would detect and track the OS, while maneuvering to rendezvous. The OS would be captured via a basket, sealed into an outer container, and placed in an EEV. Nominally, within ~3 months, the orbiter would leave Mars on a non-impact trajectory to Earth, and shortly before arrival, would target Earth, release the EEV, and then divert away from Earth. The EEV would enter and hard land at a recovery site to be determined (baselined to be UTTR, decision pending the National Environmental Policy Act [NEPA] process and agreement with the U.S. Air Force). This return trajectory and EDL sequence is similar to the Genesis and Stardust missions, except it would not have a parachute.

The MRS element would then be responsible for safe transport of the EEV to a sample receiving facility (SRF), where the hardware and samples would remain in quarantine until they are determined to be safe (either by their nature or sterilized). A testing protocol would be applied to the samples to determine if they are safe for release. This might take approximately one year and is considered part of the MRS element. If the samples are determined to be non-hazardous to Earth's biosphere, the samples would be released to a curation facility for safe keeping and distribution to the international science community. A nominal cost is included for such a facility, potentially part of the current NASA Johnson Space Center (JSC) curation facilities. While they are not costed in this study, options for conducting science in the SRF are being considered in the event the samples are not deemed safe to release.

The orbiter was designed and costed by JPL's Team X, assuming an in-house build. Alternatively, the orbiter could be built by an industry partner, or provided by ESA as part of an ongoing international partnership on Mars missions. The EEV most likely would be provided by NASA Langley Research Center (LaRC), the developers of the EEV to this point. MRS would be implemented by NASA with potential help from other agencies for safe transport of the EEV. A new SRF is planned, but augmentation to an existing bio-safety level-4 (BSL-4) lab would be considered. Curation nominally would fall under the auspices of the existing Astromaterials Curation Laboratory at the NASA JSC, and could be part of the SRF. Although, not considered in this report, ESA could provide support or parallel facilities for MRS.

### Concept Maturity Level

Table 2-1 summarizes the NASA definitions for concept maturity levels (CMLs). The flight systems concept is at a maturity level of CML 4.

The orbiter concept has been through several iterative Team X studies, and is mostly based on Mars orbiters currently flying. The EEV was brought to a detailed conceptual design by NASA LaRC in 2002, and the design is still judged to be valid and appropriate for the mission.

The MRS element is based on studies performed by three industrial teams in 2005, establishing and evaluating conceptual plans. This element is at CML 3.

**Table 2-1. Concept Maturity Level Definitions**

<b>Concept Maturity Level</b>	<b>Definition</b>	<b>Attributes</b>
CML 6	Final Implementation Concept	Requirements trace and schedule to subsystem level, grassroots cost, V&V approach for key areas
CML 5	Initial Implementation Concept	Detailed science traceability, defined relationships and dependencies: partnering, heritage, technology, key risks and mitigations, system make/buy
CML 4	Preferred Design Point	Point design to subsystem level mass, power, performance, cost, risk
CML 3	Trade Space	Architectures and objectives trade space evaluated for cost, risk, performance
CML 2	Initial Feasibility	Physics works, ballpark mass and cost
CML 1	Cocktail Napkin	Defined objectives and approaches, basic architecture concept

## Technology Maturity

The Orbiter Mission would use the heritage and experience from a decade of orbiters at Mars. The orbiter bus, per se, would have no new technologies. Rendezvous and capture at Mars would be new, but concerns are mitigated by the experience of the DARPA Orbital Express mission, which performed detection, rendezvous, and capture in Earth orbit under very similar conditions, and demonstration of a MSR capture basket concept on a zero-g aircraft campaign. While the required rendezvous components have heritage from prior programs, integration as a system would still be required. The capture system would still need further development and integration with the rendezvous system would need to be demonstrated to reach technology readiness level (TRL) 6 by Preliminary Design Review (PDR).

Early development and testing of the EEV concept has taken the design far enough to mitigate concerns. The biggest challenge ahead is meeting the planetary protection requirements for a restricted Earth-return mission (termed BPP). A PRA has indicated where development is needed, some of which has been satisfied by the EEV concept. While basic techniques have been demonstrated in labs, components for sealing, leak detection, and dust mitigation still need to be brought up to TRL 6. In addition, the design of the EEV needs to be refreshed and the system developed to the point that it could be flight tested, if needed, by PDR.

## Key Trades

Many trade studies for MSR have been performed over the last decade. For the orbiter concept, main trades have included potential use of solar electric propulsion (which would not be mission enabling), a rendezvous location (500 km circular being a good match for the proposed MAV capability vs. deep-space or high-altitude), direct entry at Earth (vs. returning to the Space Station or Earth orbit, neither of which meets the reliability needed for planetary protection), and passive optical rendezvous sensing (simple, reliable and adequate vs. active systems).

Orbiter implementation approach details still have open trades, which would be resolved after selection of the implementer (a NASA center, industry, or the European Space Agency [ESA]). The largest looming trade is staging of the propulsion system, either after Mars Orbit Insertion (MOI), Trans-Earth Injection (TEI), or both. While these alternate staging designs have been analyzed (and result in lower launch mass), a single stage is baselined in this report as being the most conservative.

The main trades of MRS implementation would involve the SRF and curation facility. The SRF might either be a new stand-alone facility or an augmentation to an existing BSL-4 laboratory (budget assumes a new facility). The curation facility might either be part of the SRF or a new lab built in conjunction to existing NASA JSC curation labs (assumed in the budget). Potential partnership with ESA might lead to their support to either, or even provision of parallel labs.

# 3. Technical Overview

## Instrument Payload Description

It is assumed there are no science instruments proposed for MSR Orbiter.

Instrumentation for planetary protection (not science) sample hazard testing in the SRF is included in the cost provided by industry teams, as part of the facility.

## Flight System

The description is divided into two flight systems—the orbiter bus with a rendezvous/capture subsystem and the EEV.

### *Orbiter*

The series of Mars orbiters (Mars Global Surveyor [MGS], Odyssey [ODY], Mars Reconnaissance Orbiter [MRO]) over the last decade lay the foundation for the proposed MSR Orbiter, including bus subsystems, complex operations at Mars, aerobraking (needed to reduce fuel requirements), and telecomm relay for assets on the surface.

The primary function of the orbiter would be to detect, rendezvous, and capture the OS, transfer the OS to an EEV, then target and release the EEV to Earth for entry. This would all need to be performed in a manner consistent with the planetary protection of Earth (discussed in the Planetary Protection section).

Depending on whether there are adequate telecomm assets at Mars for critical event coverage and surface vehicle telecomm relay, the orbiter might need to provide this function, in which case it would have to be early in the mission sequence as baselined. The orbiter would have redundant Electra telecomm relay systems and an X-band Small Deep Space Transponder Earth link with a 2-axis gimbaled 1 m high-gain antenna. Electra is the standard programmable radio that has flown on MRO. It has a highly sensitive broadband-receiving mode originally designed for monitoring a potential ultra-high frequency (UHF) beacon on the OS, which might be included for backup.

Even with the benefit of aerobraking to reduce MOI propulsive requirements, fuel would comprise approximately two thirds of the orbiter's mass because of the additional need to perform a TEI to return. A bi-propellant system would be utilized for efficiency, like MGS. Figure 3-1 shows the baseline orbiter concept developed by JPL's Team X. While the baseline in this report assumes one EEV, the configuration shows accommodation of two. Table 3-1 provides a mass summary and Table 3-2 lists the proposed orbiter characteristics. The bulk of the configuration would be a large central hydrazine fuel tank with two outboard NTO oxidizer tanks. A reaction control system (RCS) for attitude control would use hydrazine only. Power would be provided by a single 4.3 m diameter Ultraflex solar array, and a second dummy (unpopulated) array would be added to provide additional cross-sectional area (more drag) to keep the aerobraking period within 6–9 months. Except for the payload (rendezvous hardware and EEV), all other subsystems would be standard heritage hardware, depending on the integrator (a NASA center, industry, or ESA). The specifics in this report assume JPL in-house implementation consistent with standard Team X study assumptions. The baseline design is redundant throughout.

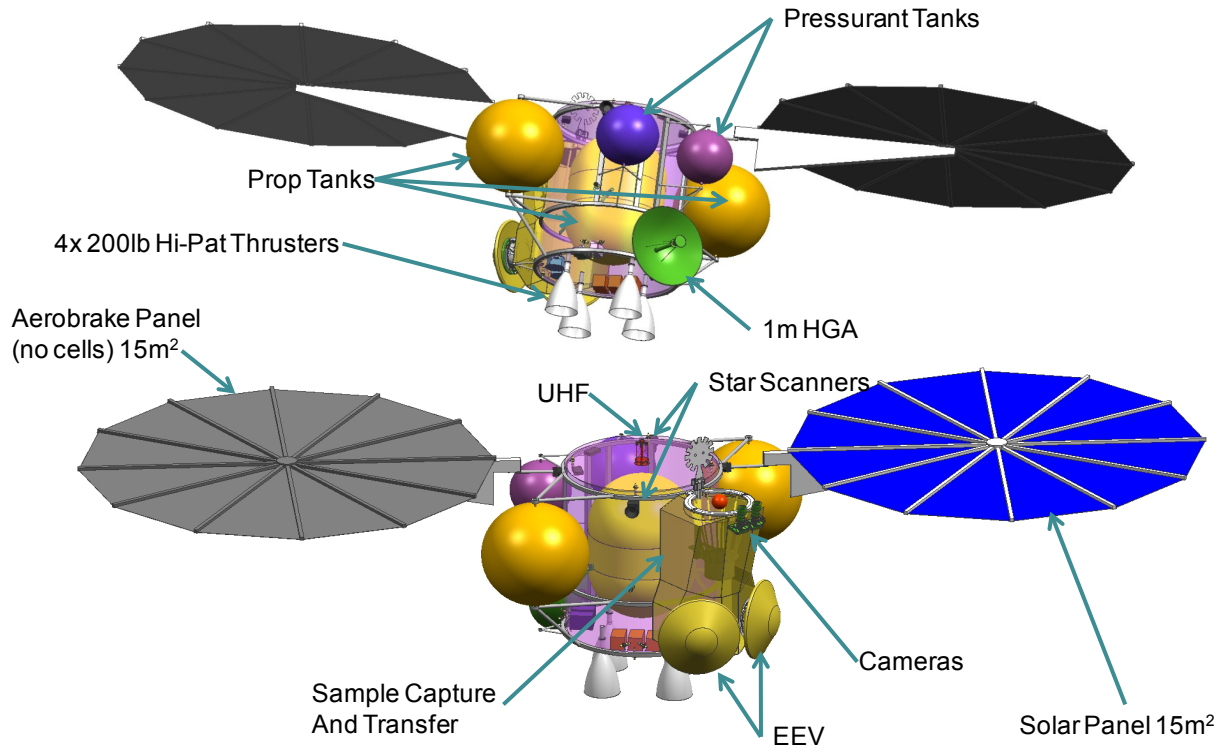

**Figure 3-1 Preliminary Orbiter Configuration**

**Table 3-1. Orbiter Bus Mass and Power Estimates**

	Mass			Average Power		
	CBE (kg)	% Cont.	MEV (kg)	CBE (W)	% Cont.	MEV (W)
Structures & mechanisms	260.9	30%	339.2	-	-	-
Orbiter launch vehicle adapter	22.6	30%	29.3	-	-	-
Thermal control	28.1	27%	35.6	67	43%	96
Propulsion (dry mass)	137.5	25%	171.9	69	43%	99
Attitude control	29.0	21%	35.1	66	43%	94
Command & data handling	20.4	30%	26.6	40	43%	57
Telecommunications	29.1	13%	32.9	145	43%	207
Power	98.8	30%	128.4	57	43%	81
Cabling	33.0	30%	42.9	-	-	-
System contingency	-	-	101.1	-	-	-
<b>Total Orbiter Dry Bus Mass</b>	<b>659.4</b>	<b>43%</b>	<b>942.9</b>	<b>444</b>	<b>43%</b>	<b>634</b>

**Table 3-2. Preliminary Orbiter Characteristics**

<b>Flight System Element Parameters (as appropriate)</b>	<b>Value/ Summary, units</b>
<b>General</b>	
Design life, months	5 years
<b>Structure</b>	
Structures material (aluminum, exotic, composite, etc.)	Primarily aluminum
Number of articulated structures	1 HGA, 1 capture door, 1 solar array, 2 rendezvous sensor
Number of deployed structures	2 solar arrays
<b>Thermal Control</b>	
Type of thermal control used	Passive with heaters
<b>Propulsion</b>	
Estimated delta-V budget, m/s	3,690 m/s
Propulsion type(s) and associated propellant(s)/oxidizer(s)	N <sub>2</sub> H <sub>4</sub> + NTO
Number of thrusters and tanks	4 x 890 N biprop main, 16 x 0.7 N mono RCS, 1 NTO tank, 2 N <sub>2</sub> H <sub>4</sub> tanks
Specific impulse of each propulsion mode, seconds	325 s main, 210 s RCS
<b>Attitude Control</b>	
Control method (3-axis, spinner, grav-gradient, etc.)	3-axis
Control reference (solar, inertial, Earth-nadir, Earth-limb, etc.)	Flight vector
Attitude control capability, degrees	505 arcsec
Attitude knowledge limit, degrees	252 arcsec
Agility requirements (maneuvers, scanning, etc.)	6.2 arcsec/sec stability
Articulation/#-axes (solar arrays, antennas, gimbals, etc.)	HGA 2DOF, one solar array 1DOF
Sensor and actuator information (precision/errors, torque, momentum storage capabilities, etc.)	0.5 deg sun sensors, 6 arcsec star trackers, 0.005 deg/hr MIMU
<b>Command &amp; Data Handling</b>	
Flight element housekeeping data rate, kbps	Low
Data storage capacity, Mbits	4 GB
Maximum storage record rate, kbps	8 Mbits/s
Maximum storage playback rate, kbps	8 Mbits/s
<b>Power</b>	
Type of array structure (rigid, flexible, body mounted, deployed, articulated)	Deployed UltraFlex
Array size, meters x meters	15 m <sup>2</sup>
Solar cell type (Si, GaAs, multi-junction GaAs, concentrators)	GaAs
Expected power generation at beginning of life (BOL) and end of life (EOL), watts	1257 W BOL, 1124 W EOL
On-orbit average power consumption, watts	634 W
Battery type (NiCd, NiH, Li-ion)	Li-ion
Battery storage capacity, amp-hours	96 A-Hr

Rendezvous and capture of a free-orbiting OS would be performed by the orbiter after aerobraking is complete. An optical navigation (OpNav) camera, demonstrated on MRO would be used to find and track the OS, while a very-low duty cycle UHF beacon on-board the OS could be used as a backup aid if the location is grossly unknown. The camera was designed to detect the orbiting OS from a distance of as far as 10,000 km. After the orbiter closes in on the OS in a safe, non-colliding, co-elliptical orbit, the last tens of meters would have to be performed autonomously (Figure 3-2). The Draper Laboratory Inertial Stellar Compass (ISC) package flown on ST-6 is baselined as the pointing and wide angle (close proximity viewing) self-contained system with the OpNav camera added. An off-the-shelf gimbal would provide articulation of the tracking system. Two redundant systems are planned. Coupled RCS thrusters would provide fine control of the orbiter state vector for closure on the OS with millimeter/sec granularity. In 2007, DARPA's Orbital Express demonstrated optical tracking and autonomous rendezvous and capture of a passive small satellite in Earth orbit with conditions representative of those that would be needed by MSR at Mars [3]. The process and algorithms confirmed those planned for MSR.

Capture would be accomplished via a capture basket as shown in Figure 3-2. The JPL capture basket design concept has been demonstrated on the NASA C-9 zero-g aircraft flight campaign with more than 100 zero-gravity parabolic runs [4]. After capture, the OS would be transferred to the EEV for return to Earth. In that process, the OS could be sealed in a brazed container, in a way that the transfer to the EEV would be Mars-contaminant free. The capture and transfer hardware would be ejected prior to leaving Mars, if analysis indicates that this would be necessary to break the chain of contact with Mars.

Appendix C provides the master equipment list (MEL) for the proposed orbiter.

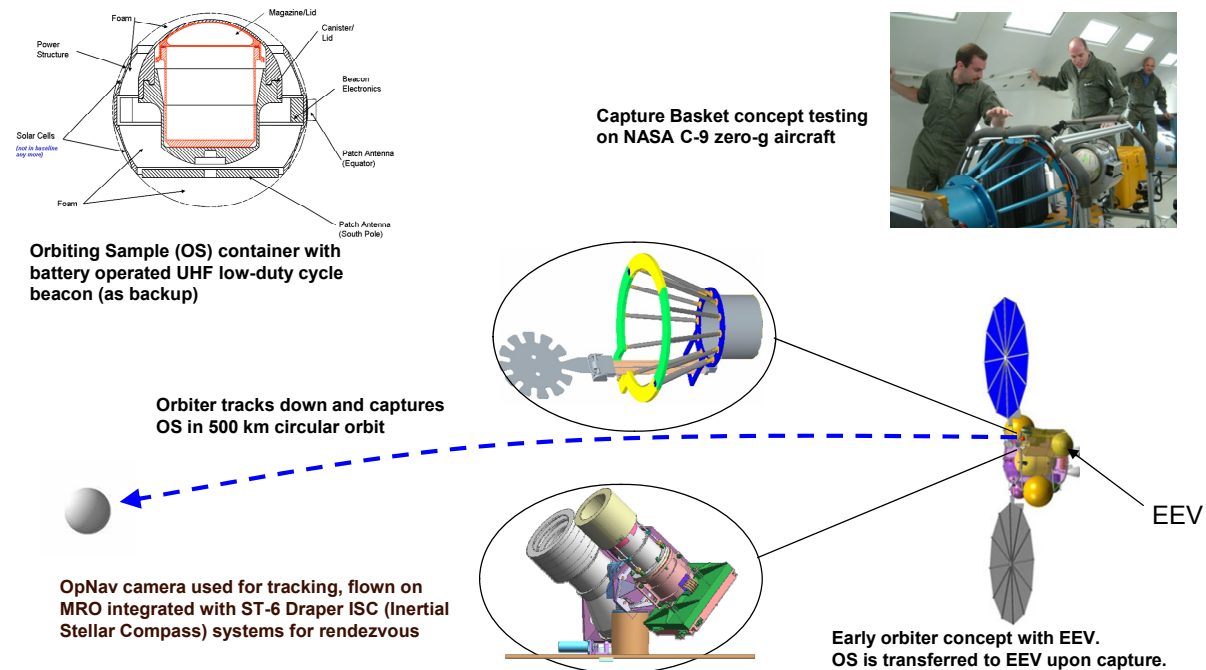
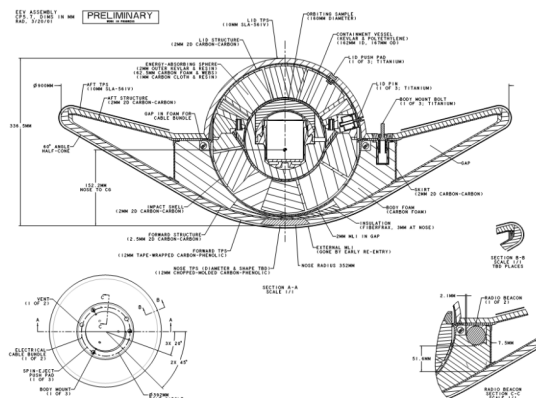

**Figure 3-2. Rendezvous and Capture System Concept**

## Earth Entry and the Earth Entry Vehicle Preliminary Design

The return to Earth would be via a biased non-Earth-impact trajectory. The orbiter would target toward Earth several days prior to EEV release, nominally entry-minus-4 hours, and then divert away from Earth following EEV release. The return and entry process is modeled after the Stardust and Genesis missions that successfully landed at the UTTR. However, steps would be taken to guarantee a higher degree of reliability (such as added redundancy and cross-checking trajectory planning by multiple teams). Unlike Genesis and Stardust, the MSR EEV would also be parachute-less and self-righting (tumble-free) during atmospheric entry, eliminating these failure modes. A preliminary LaRC design reached a high degree of maturity in 2000 and still holds up to scrutiny (see [5] for details). A full-scale (0.9 m diameter) developmental model was impact tested at UTTR, dropped from high-altitude, reaching terminal velocity (Figure 3-3). In addition, wind-tunnel testing and high-fidelity simulations have been performed that show that the vehicle would right itself into a stable orientation prior to the entry heat-pulse, even if released backwards or tumbling. The heat-shield material of choice for the EEV would be carbon phenolic, with very high heritage and reliability established by the Department of Defense (DOD). The technology program would refresh the design and finish development by PDR. The EEV design would be ready for flight testing by PDR if determined necessary; however, flight testing is currently considered optional.

The EEV would be completely passive, except for self-contained range beacons that would be initiated at entry. The structure would be carbon-carbon, supporting the carbon phenolic heat shield. Titanium would be considered as an alternate structure material. The impact shield would be an energy absorber made up of cells of carbon foam with resin-impregnated Kevlar and carbon walls. The OS would fit in the center of the EEV, inside a 5 mm-thick flexible rubberized Kevlar containment vessel that would be sealed in Mars orbit before return toward Earth. Mechanical latches would be used to secure the lid (top half) of the EEV, once the OS is inserted. Table 3-3 lists the mass breakdown of the EEV design (power estimates are not applicable for this passive design).



Preliminary EEV Design

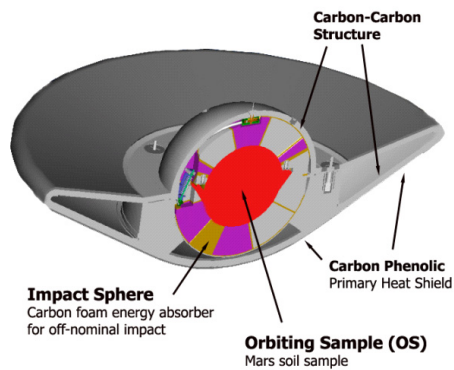

LaRC's chuteless EEV Concept



EEV development model dropped tested at UTTR, reached terminal velocity

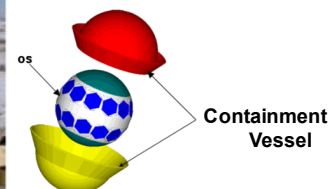

**Figure 3-3. Earth Entry Vehicle Preliminary Design**

**Table 3-3. Earth Entry Vehicle Mass and Power Estimate**

	Mass			Average Power		
	CBE (kg)	% Cont.	MEV (kg)	CBE (W)	% Cont.	MEV (W)
Structures and mechanisms	16.5	43%	23.6	-	-	-
Thermal control	0.4	43%	0.6	-	-	-
Thermal protection system (TPS)	15.7	43%	22.5	-	-	-
Range beacons	0.1	43%	0.2	-	-	-
Sensors and cables	0.3	43%	0.4	-	-	-
<b>Total EEV Dry Mass</b>	<b>33.0</b>	<b>43%</b>	<b>47.2</b>	-	-	-

### **Mars Returned Sample Handling Concept**

MRSH denotes the “ground segment” of the proposed MSR mission, i.e., the activities occurring after landing of the sample return capsule on Earth. The most recent National Research Council (NRC) study, Assessment of Planetary Protection Requirements for Mars Sample Return Missions [6], as well as previous studies referenced therein, included high-level recommendations for MRSH. Discussion of the ground segment of MSR often emphasizes the planetary protection aspects, which take the form of policy. However, the ground segment represents a broad multifaceted element of MSR, and would include landing site operations, Earth surface transportation, the SRF (one or more), and curation (e.g., the formal record-keeping, storage, protection, and distribution) of the samples over time (Figure 3-4).

After landing, MSR would require that the whole EEV be put in a quarantine vault with cooling (to maintain sample integrity) as soon as possible, and be securely transported to the SRF.

The SRF represents the facility and processes that would be needed to

- Handle the samples (and vehicle) in a manner as if they are potentially hazardous materials
- Keep the samples isolated from Earth-borne contaminants
- Apply a rigorous protocol to determine if there is any hazard in potentially releasing samples to other laboratories outside the facility

The NASA Planetary Protection Officer commissioned the development of a draft test protocol that would represent one “necessary and sufficient” approach to evaluate the safety of the samples while safeguarding the purity of the samples from terrestrial contamination. A Draft Test Protocol for Detecting Possible Biohazards in Martian Samples Returned to Earth was published in October 2002 [7]. In 2003, three architectural design teams independently examined the scope, approach, cost, and technology required for the SRF, using the Draft Test Protocol for requirements. The approaches varied from all-robotic handling of samples to more traditional glove box implementations. The studies indicated that the principles and techniques required are generally mature. Biosafety laboratories, the NASA Lunar Sample Facility, pharmaceutical laboratories, and electronic fabrication cleanrooms perform most of the required individual functions. However, there are some areas needing early development, such as ensuring sample preservation and bio-safety together, representing new challenges that were addressed by techniques like dual-walled containers (and gloves) with positive pressure clean inert gas in between the walls. This, as well as some further development in ultra-clean sample manipulation, safe and pure transport of samples, and sample sterilization techniques, are planned in the technology program.

Future studies would explore the possibility of implementing an SRF at or adjacent to an existing BSL-4 facility since containment at BSL 4 is consistent with MSR’s containment requirements. However, BSL facilities do not have and do not meet science contamination requirements that would be imposed on a sample returned from Mars. For that reason, MSR mission cost estimates assume the development of a new facility. In addition, if MSR becomes an international program, there likely would be interest in more than one SRF.



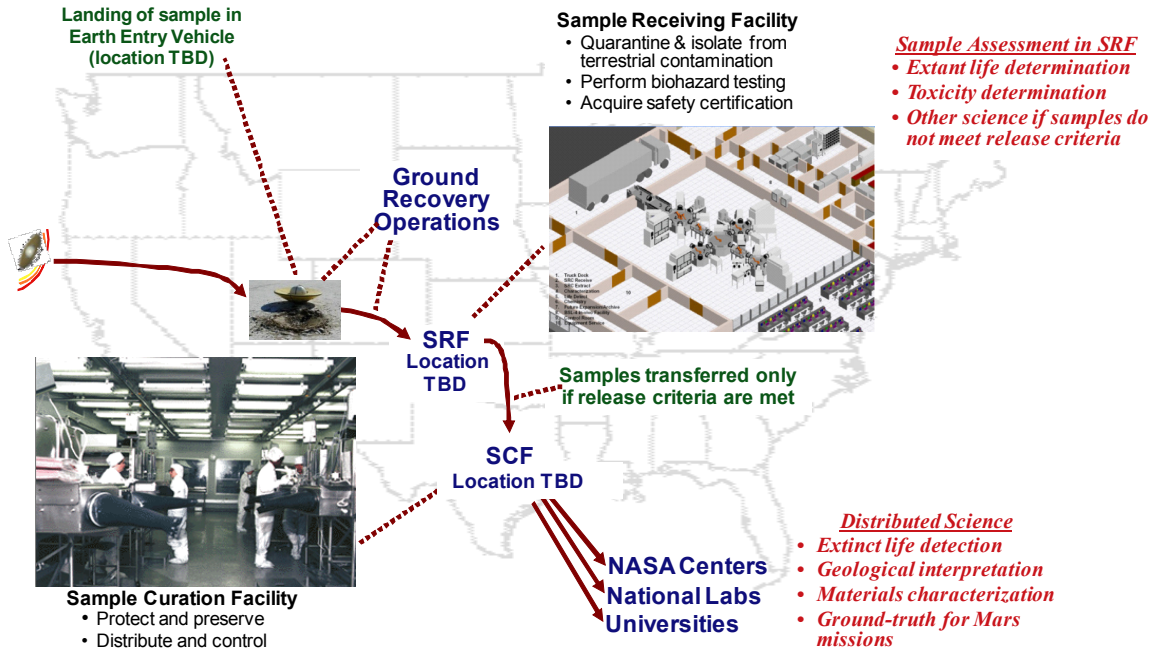

**Figure 3-4. Mars Returned Sample Handling Concept**

If the samples are certified non-hazardous, they could be transferred to a curation facility (potentially at NASA-JSC in association with the established Astromaterials Curation Laboratory). Project costs assume nominal development of this laboratory. Curation functions would include long-term pristine sample storage, sample processing, and controlled distribution to outside investigators potentially around the world. As continues today with the Apollo lunar samples, the Martian samples would be amongst the most carefully studied materials in history, not only by biologists, but also by geologists, geochemists, and atmospheric scientists. While the estimated cost for a nominal facility is included in MRSR, the ongoing decades of curation and controlled distribution is outside the scope of this study.

A comprehensive overview of the SRF design studies, including cost and background, can be found in [8], attached as Appendix D.

## Concept of Operations and Mission Design

The sequence of operations in the proposed Orbiter Mission has been discussed throughout this report. Table 3-4 provides the mission and system parameters for the mission preliminarily planned for 2022.

To be conservative, the use of the Atlas-551 has been used for costing; however, the mission would likely be able to use an Atlas with fewer strap-on solid rockets motors.

This proposed mission is preliminarily planned for launch in 2022. The parameters in Table 3-4 reflect that opportunity. Table 3-5 compares mission parameters with the 2022 performance enveloping the performance challenges for the rest of the decade. The skipped opportunity listed for TEI is for the baseline of sending the orbiter first and the lander in the second opportunity, and returning in roughly the third opportunity (see Figure 3-5).

The baseline mission sequence would send the orbiter in 2022 and the lander in 2024, with return in 2026. Return to Earth would take ~9 months for most opportunities, but returning in 2022 through 2026 would have the arrival of the EEV in Earth's southern hemisphere, and would require a 6-month swingby to reach a northern hemisphere landing site such as UTTR.

**Table 3-4. Mission Design Concept**

Parameter	Value	Units
Orbit parameters (apogee, perigee, inclination, etc.)	500 km circular orbit, within +/-30 deg incl.	–
Mission lifetime	5	years
Maximum eclipse period	42	minutes
Launch site	CCAFS	–
Total orbiter mass <b>with</b> contingency	943	kg
Total EEV <b>with</b> contingency	47	kg
Propellant mass <b>without</b> contingency	1,573	kg
Propellant contingency	45	%
Propellant mass <b>with</b> contingency	2,280	kg
Launch adapter mass <b>with</b> contingency (included in orbiter mass)	30	kg
Total launch mass	3,270	kg
Launch vehicle	Atlas 551	type
Launch vehicle lift capability	4,770	kg
Launch vehicle mass margin	1,500	kg
Launch vehicle mass margin (%)	31	%

**Table 3-5. Comparative Mission Parameters**

Launch Year	Type	C <sub>3</sub> (km <sup>2</sup> /sec <sup>2</sup> )	Atlas 551 Capability (kg)	Max MOI (km/sec)	Return*	
					TEI Depart (km/sec) Next	Skipped
2018	I	9.8	5,300	1.2	2.5	2.5
2020	I	14.3	4,900	1.1	2.5	2.2
2022	II	15.9	4,770	1.1	2.2	2.0
2024	II	12.1	5,100	0.9	2.0	2.0
2026	II	10.5	5,250	1.0	2.0	1.9
2028	II	10.4	5,260	1.2	1.9	2.0

\*Next opportunity ~2 years after launch; skipped ~4 years after launch.

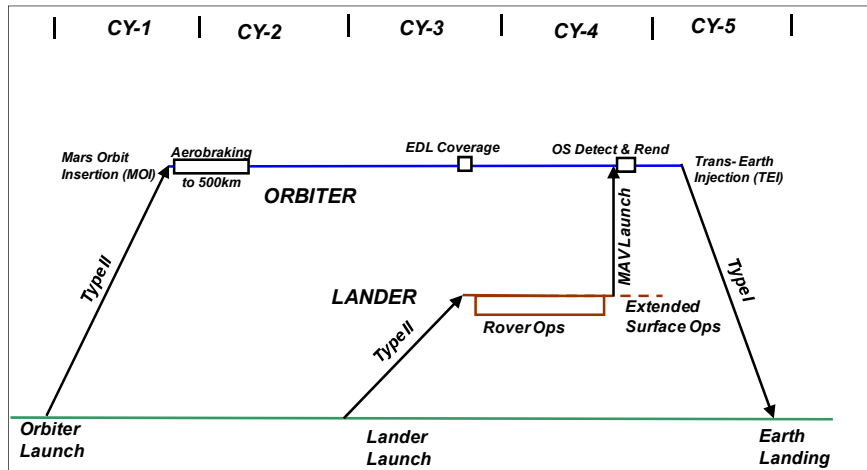

**Figure 3-5. Generic Mission Timeline**

For this proposed Orbiter Mission, launch is scheduled for 9/2022, arriving at Mars in 8/2023, leaving Mars in 8/2026, and landing on Earth in 12/2027 (which would include the 6-month swingby to be able to land in the northern hemisphere). The launch window is assumed to be the traditional 20 days for Mars missions.

Communications for the proposed Orbiter Mission would be through the Deep Space Network (DSN). Table 3-6 summarizes the need for coverage, consistent with previous Mars orbiters. Note that without science instruments, the data volume would be low, so X-Band would be adequate. The Decadal Survey guidelines indicate that Ka-Band should be used post 2018. It is believed that X-band might still be available; however, Ka-Band could be used, with a cost of \$5M–\$10M and insignificant impact on mass and volume.

**Table 3-6. Mission Operations and Ground Data Systems**

Downlink Information	Nominal Phases	Rendezvous	Aerobraking	Maneuvers
Number of contacts per week	7	Continuous	14–21	Continuous
Number of weeks for mission phase, weeks	Throughout	3 weeks	9 months	6 days each x 12
Downlink frequency band, GHz – 8.4 GHz	X-Band	X-Band	X-Band	X-Band
Telemetry data rate(s), kbps	10 kbps	10 kbps	10 kbps	10 kbps
Transmitting antenna type(s) and gain(s), DBi	1.0 m HGA	1.0 m HGA	1.0 m HGA	1.0 m HGA
Transmitter peak power, watts				
Downlink receiving antenna gain, DBi	34 m DSN	34 m DSN	34 m DSN	34 m DSN
Transmitting power amplifier output, watts	17 watts	17 watts	17 watts	17 watts
Total daily data volume, (MB/day)	<b>170 Mb</b>	<b>170 Mb</b>	<b>170 Mb</b>	<b>170 Mb</b>
Uplink Information				
Number of uplinks per day	1 per day	Several	Several	Several
Uplink frequency band, GHz – 7.2 GHz	X-Band	X-Band	X-Band	X-Band
Telecommand data rate, kbps	2 kbps	2 kbps	2 kbps	2 kbps
Receiving antenna type(s) and gain(s), DBi	1.0 m HGA	1.0 m HGA	1.0 m HGA	1.0 m HGA

## Planetary Protection

The orbiter must meet the requirements for Category III (forward planetary protection). This level of requirements has been implemented in all past Mars orbiters, with procedures like trajectory biasing, analysis, and selected bake-out of subsystems, all included in the cost.

The main challenge for the proposed Orbiter Mission would be to meet the BPP requirements of Category V, restricted Earth return. Preventing contamination of Earth by potentially bio-hazardous Martian material would require highly reliable sample containment and ultra-safe entry and landing on Earth, as well as breaking-the-chain-of-contact with Mars in a way that would preclude return of Mars organisms outside of the sample containment. The current MSR architecture and plans reflect these implementation features, and the MSR technology program includes continued development of capabilities not yet fully demonstrated as outlined in the Technology Development Plan section. A PRA has been used to guide selection of techniques and will continue to be updated as trades and technology alternate paths are selected.

Breaking-the-chain-of-contact has several features to it, including ensuring that the samples would be sealed in a reliable container. Nominally, the OS would be sealed into a container that would be brazed shut at the orbiter. In addition, there cannot be any Mars organisms outside the sealed container that could return to Earth. This could be implemented by minimizing Mars dust transfer from the MAV by keeping it in a non-contaminated cocoon, shedding atmospheric dust during launch, and allowing time for the OS to be in free-space before contact with the orbiter. The equipment deck of all the capture and transfer hardware could be ejected prior to leaving Mars if analysis determines it necessary. The EEV would be in a biobarrier, which would also provide micrometeoroid protection. A belt-and-suspenders approach is planned, diverting the orbiter into a non-Earth impact trajectory and designing the EEV so that all external surfaces reach sterilization temperatures upon entry.

## Risk List

Table 3-7 lists the top mission and implementation risks for the proposed Orbiter Mission and MRSH. Figure 3-6 correlates the likelihood and impact on a 5x5 risk matrix (with risk level color coding of green = low, yellow = medium, and red = high). Table 3-8 is a key to risk assessment.

**Table 3-7. Top Risks for the Proposed Orbiter Mission and MRSB**

Risk	Level	Description	Impact	Likelihood	Mitigation
1. Lander is late in delivery of the OS for rendezvous.	M	If the rendezvous is not completed in time for planned Earth return, the return would be delayed by 2 years.	5	2	Carry the fuel to support a 2 or more year slip in return.
2. OS capture difficulties might require several attempts.	M	Each attempt uses fuel and ultimately might cause delayed return.	5	2	Carry the fuel to support such difficulties.
3. Difficulty in meeting the restricted Earth-return planetary protection requirements.	M	Some technologies are still needed to support the series of statistical mitigation factors. A statistically satisfactory solution set is needed for launch approval. The mission could be delayed until resolved and the design could become more complex.	4	3	Parallel solutions are being pursued in the technology program, targeting completion by PDR. A PRA is used to guide choices.
4. The NEPA process delays the start of the SRF.	L	The NEPA process has realized delays in BSL-4 facilities, and the same could happen with the SRF. The mission would be delayed until the SRF is near complete.	2	2	Build in additional schedule to accommodate as much as a 2-year delay. The schedule as costed has conservatism built-in. Return could be delayed by 2 years if needed.

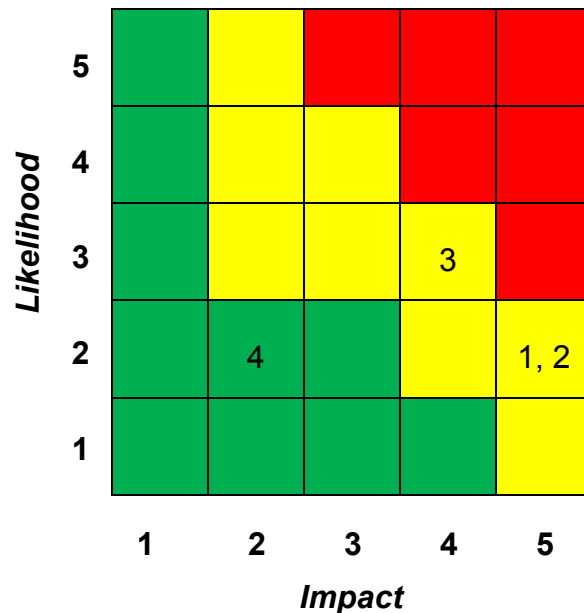

**Figure 3-6. 5 x 5 Risk Matrix**

**Table 3-8. Risk Level Definitions**

Levels	Mission Risk		Implementation Risk	
	Impact	Likelihood of Occurrence	Impact	Likelihood of Occurrence
5	Mission failure	Very high, ~10%	Consequence or occurrence is not repairable without engineering (would require >100% of margin)	Very high, ~70%
4	Significant reduction in mission return (~10% of mission return still available)	High, ~5%	All engineering resources will be consumed (100% of margin consumed)	High, ~50%
3	Moderate reduction in mission return (~50% of mission return still available)	Moderate, ~1%	Significant consumption of engineering resources (~50% of margin consumed)	Moderate, ~30%
2	Small reduction in mission return (~90% of mission return still available)	Low, ~0.5%	Small consumption of engineering resources (~10% of margin consumed)	Low, ~10%
1	Minimal (or no) impact to mission (~99% of mission return still available)	Very low, ~0.1%	Minimal consumption of engineering resources (~1% of margin consumed)	Very low, ~1%

# 4. Development Schedule and Schedule Constraints

## High-Level Mission Schedule

Figure 4-1 shows the development schedule for the proposed Orbiter Mission (planned for launch in 2022) and the proposed SRF, which is the core of MRSH. It also shows an early NEPA process (with Notice of Intent [NOI] milestones) necessary to ensure adequate time to support return of samples in 2027. Table 4-1 lists the duration of key phases of proposed Orbiter Mission development.

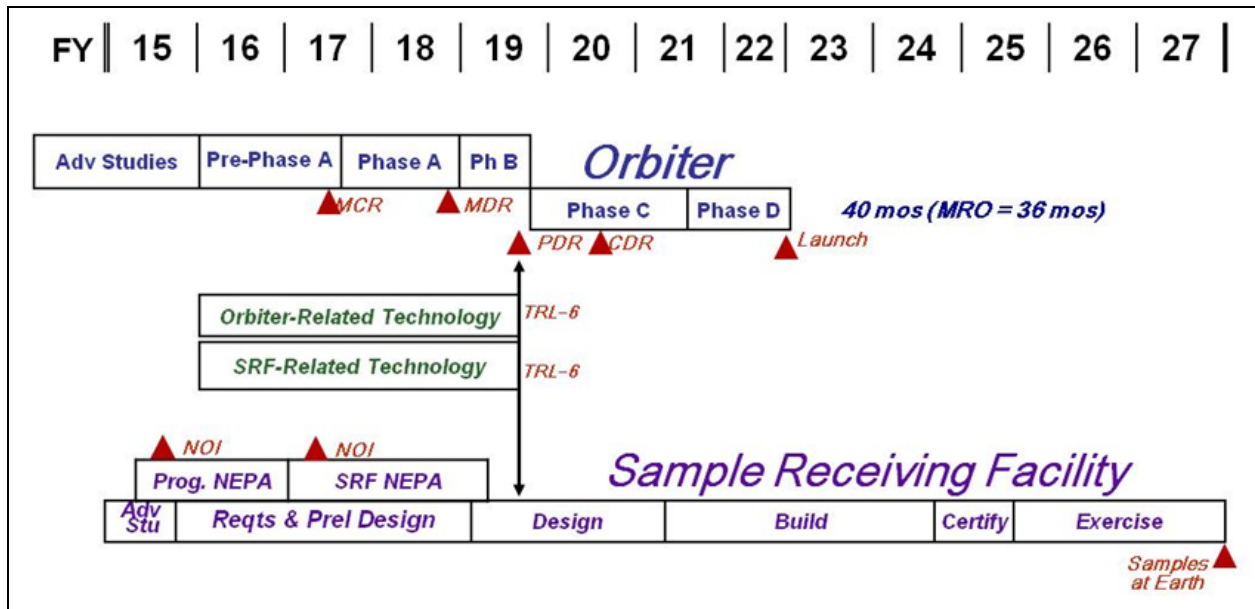

**Figure 4-1. Development Schedule for the Proposed Orbiter Mission and MRSR**

**Table 4-1. Proposed Key Phase Duration**

Project Phase	Duration (Months)
Phase A – Conceptual Design	17 months
Phase B – Preliminary Design	10 months
Phase C – Detailed Design	22 months
Phase D – Integration & Test	18 months
Phase E – Primary Mission Operations	63 months
Phase F – Extended Mission Operations	None
Start of Phase B to PDR	8 months
Start of Phase B to CDR	20 months
Project total funded schedule reserve	Built in to schedule (~1 month/year)
Total development time Phase B–D	50 months

# Technology Development Plan

Three areas require technology development: 1) rendezvous and capture, 2) BPP, including the EEV, and 3) technologies for handling samples in the SRF.

All three areas will be developed over about a 4-year period leading to TRL 6 by PDR as indicated in the development schedule above. The cost for technology development is included and identified as a line item in the overall mission and MRSR costs listed in Table 5-1.

## ***Rendezvous and Capture***

The following tasks are planned:

- Combine a version of the OpNav camera flying on MRO with a ST-6 Draper ISC package for a complete autonav system.
- Select and integrate autonav algorithms proven on Orbital Express, DS-1, and Deep Impact.
- Develop a simple light source for proximity operation during eclipse.
- Develop a UHF beacon and power source for the OS (bird collar and solar cell hardware)
- Perform further refinement, trades, and testing of the capture system.
- Integrate hardware in the loop testing.

Except for the UHF beacon, enough work has been done to lend confidence that the tasks would be successful. The beacon for the OS is optional, but would provide some measure of backup in locating the OS. It would not be enabling.

## ***Back Planetary Protection***

BPP would require a complex and many-faceted approach and an end-to-end solution to meet the stringent restricted-Earth-return planetary protection requirements. Systems engineering and PRA analysis would overlay these activities to provide the proper guidance and decision-making process that would lead to successful development.

Specific tasks preliminarily planned (plan will be kept flexible) are:

- Develop sealing techniques for the OS. Explosive welding and brazing have been demonstrated at TRL 3–4. This work needs to continue and be down-selected within the first 2 years.
- Study and develop dust mitigation techniques. There are several techniques available, but analysis still needs to be performed to down-select.
- Develop a leak detection (preferably wireless) technique to ensure that the OS is not compromised. Preliminary proof of concept has demonstrated via a Small Business Innovation Research (SBIR) task in 2005.
- Select materials for the OS, CV, and EEV to ensure meteoroid protection (and landing protection) with high probability. Initial considerations are aluminum with high-density foam OS, rubberized-Kevlar “bag” CV, high density foams, and removable EEV meteoroid shields. In addition, detection of shield penetration could be used. Multiple solutions are available, but they need to be developed far enough in the first 1.5 years to be down-selected for further testing. Hyper-velocity testing of the Kevlar CV materials have been performed in the past but stopped prematurely due to loss of funding.
- Refresh the EEV design, test existing TPS, and put developmental models through a variety of testing by PDR.



## ***Mars Returned Sample Handling***

The main challenge for MRSB would be sample cleanliness while ensuring containment. A few areas need more development—double-walled containment vessels, rapid transfer ports, and double-walled gloves. In addition, robotics for sample manipulation and common carriers need to be developed. While these areas are not new to industry, they need tailoring to meet MRSB purposes. In addition, sterilization techniques need to be further studied and developed.

## **Development Schedule and Constraints**

There is nothing unusual about the proposed Orbiter Mission that would indicate schedule issues at this point of planning. Care has been taken to adequately plan technologies and advanced development (i.e., with the EEV) to be completed prior to PDR.

Launch opportunities occur roughly every 26 months; thus, if the spacecraft was not ready for launch, a 2-year slip would occur.

# 5. Mission Life-Cycle Cost

## Costing Methodology and Basis of Estimate

The proposed Orbiter Mission design and cost is provided by JPL's Team X using their quasi-grassroots process. Combinations of grassroots, parametric analysis, and analogy models are used by each of the discipline chairs representing their implementing organizations. These models have been validated against actual costs of prior JPL missions.

The Team X study was performed in October 2009. Costs have been modified to meet the Decadal Survey guidelines of 50% reserves for development (Phases A–D) and 25% for operations (Phase E).

The EEV costs date back to 2002, when NASA LaRC last completed a grassroots cost estimate based on their mature concept.

All costs have been inflated to fiscal year (FY) 2015 dollars as requested by the Decadal Survey.

Launch vehicle cost is as specified in the Decadal Survey ground rules for mission studies.

MRSH cost estimates have 50% reserves, and are based on results of industry studies (described in Appendix D).

Technology development costs are based on estimates from the potential implementing organizations at JPL and other NASA centers, and have 50% reserves.

## Cost Estimates

Table 5-1 summarizes the total mission costs for the proposed Orbiter Mission, and the cost estimate for MRSH through two years of operations for testing the sample before potential release.

**Table 5-1. Total Estimated Mission Cost Funding Profile**

(FY Costs in Real Year Dollars, Totals in Real Year and 2015 Dollars)

FY	2016	2017	2018	2019	2020	2021	2022	2023	2024	2025	2026	2027	2028	2029	Total RY	Total FY15
<b>ORBITER MISSION</b>																
<b>Pre-Phase A</b>	10	10													20	21
<b>Technology Development</b>	20	47	58	32											157	149
<b>Development A–D</b>																
Mission PM/SE/MA		1	6	19	27	27	27								107	92
EEV			2	6	9	9	9								35	30
Orbiter		5	27	62	92	100	90								376	325
MSI&T			1	5	15	16	17								54	46
Ground Data System Dev			1	3	4	4	4								16	16
Mission Design			1	4	6	6	6								23	19
Total A–D w/o Reserves		6	38	99	153	162	153								611	531
A–D Reserves		3	19	50	77	81	77								307	265
<b>Total A–D Cost</b>		9	57	149	230	243	230								918	796
<b>Launch Services</b>					100	129	70								299	257
Phase E Costs								16	16	17	18	13			80	62
Phase E Reserves								4	4	4	5	3			20	15
<b>Total Phase E</b>								20	20	21	23	16			100	77
<b>DSN</b>					1	1	1	9	10	10	10	8			50	36
<b>Education/Outreach</b>					1	1	1	1	1	1	1	1			8	7
<b>Total Mission Costs</b>	30	66	115	181	332	374	302	30	31	32	34	25			1552	1343
<b>MRSB</b>																
Technology Development	5	10	12	8											35	33
MRSB Dev & Operations	4	10	12	27	12	218	22	65	38	32	33	32	22	10	537	438
<b>Total MRSB</b>	9	20	24	35	12	218	22	65	38	32	33	32	22	10	572	471

Notes: MSI&T—Mission System Integration and Test and preparation for operations.

Includes all costs to NASA including estimated DSN costs.

# Appendix A. Acronyms

BOL	beginning of life	SEP	solar electric propulsion
BPP	back planetary protection	SRF	sample receiving facility
BSL	bio-safety level	TEI	Trans-Earth Injection
CBE	current best estimate	TRL	technology readiness level
CML	concept maturity level	UHF	ultra-high frequency
DARPA	Defense Advanced Research Projects Agency	UTTR	Utah Test and Training Range
DOD	Department of Defense		
DOE	Department of Energy		
DSN	Deep Space Network		
EDL	entry/descent/landing		
EEV	Earth entry vehicle		
EOL	end of life		
ESA	European Space Agency		
FY	fiscal year		
HGA	high gain antenna		
ISC	Inertial Stellar Compass		
JSC	Johnson Space Center		
KSC	Kennedy Space Center		
LaRC	Langley Research Center		
MAV	Mars ascent vehicle		
MEL	master equipment list		
MEV	maximum expected value		
MOI	Mars Orbit Insertion		
MRSH	Mars Returned Sample Handling		
MSR	Mars Sample Return		
NEPA	National Environmental Policy Act		
OS	orbiting sample		
PDR	Preliminary Design Review		
PRA	probabilistic risk assessment		
RCS	reaction control system		
RY	real year		
SBIR	Small Business Innovation Research		

# Appendix B. References

- [1] National Aeronautics and Space Administration. March 2010. *Mission Concept Study: Planetary Science Decadal Survey—Mars 2018 MAX-C Caching Rover*.
- [2] National Aeronautics and Space Administration. *Mission Concept Study: Planetary Science Decadal Survey—MSR Lander Mission*. In review.
- [3] Friend, R. 15 April 2008. "Orbital Express Program Summary and Mission Overview," *Proc. SPIE* **6958**, 695803.
- [4] Kornfeld, R., Parrish, J., and Sell, S. May–June 2007. "Mars Sample Return: Testing the Last Meter of Rendezvous and Sample Capture," *Journal of Spacecraft and Rockets* **44**(3).
- [5] Dillman, R., Laub, B., Kellas, S., and Schoenenberger, M. "Development and Test Plans for the MSR EEV," 2nd International Planetary Probe Workshop, August 2004.
- [6] National Research Council. 2009. *Assessment of Planetary Protection Requirements for Mars Sample Return Missions*.
- [7] Rummel, J.D. et al., eds. 2002. *A Draft Test Protocol for Detecting Possible Biohazards in Martian Samples Returned to Earth*, NASA/CP-2002-211842, National Aeronautics and Space Administration, Washington, DC.
- [8] Beaty, D., et al. 2009. "Planning Considerations for a Mars Sample Receiving Facility: Summary and Interpretation of Three Design Studies," *Astrobiology* **9**(8): 745–758, 2009, Mary Ann Liebert, Inc., publishers, [www.liebertpub.com/ast](http://www.liebertpub.com/ast).

# Appendix C. Orbiter Master Equipment List from Team X Study

Component	Fit Units	CBE/Unit (kg/unit)	CBE (kg)	Cont.	CBE + Cont. (kg)
<b>Attitude Determination and Control System</b>					
Sun Sensor 1	14	0.01	0.06	10%	0.07
Star Tracker 1	2	1.48	2.95	30%	3.84
IMU 1	2	4	8	5%	8.4
Electronics 1	3	0.99	2.97	10%	3.27
OpNav Camera Assembly (Hardware Only)	2	7.5	15	30%	19.5
OpNav Algorithms and Software	1	0	0	0%	0
Shielding:	1	0	0	0%	0
<b>Command and Data System</b>					
Processor: MSAP Enhanced SFU (3U) 133MHz	2	0.55	1.1	30%	1.43
Memory : MSL NVM / Camera Card (NR)	2	1.2	2.4	30%	3.12
Telecom I/F: MSAP MTIF Card (6U)	2	0.77	1.54	30%	2
General I/F # 1: MSAP SIA Card (6U)	2	0.8	1.6	30%	2.08
General I/F # 2: none (4000)	2		0	30%	0
Custom/Special Function Board #1: CRC Card (NR)	2	0.4	0.8	30%	1.04
CDS Backplane: MSAP Backplane	2	0.9	1.8	30%	2.34
CDS Chassis: MSAP Chassis 203x272x204 -9 cards	2	4	8	30%	10.4
CDS Power Supply: MSAP PCC DC -DC Converter: 5 V, 3.3V and +/-12V.	2	0.8	1.6	30%	2.08
MREU: MSAP Analog/Discrete MREU	2	0.8	1.6	30%	2.08
<b>Power</b>					
Solar Array	1	20.17	20.17	30%	26.22
Li-ION (Secondary Battery)	3	19.2	57.6	30%	74.88
Chassis	1	6.37	6.37	30%	8.28
Array Segment Switches* Boards	1	0.8	0.8	30%	1.04
Load Switches Boards	2	0.8	1.6	30%	2.08
Thruster Drivers* Boards	4	0.8	3.2	30%	4.16
Pyro Switches* Boards	2	0.8	1.6	30%	2.08
Houskeeping DC-DC Converters* Boards	2	1	2	30%	2.6
Power/Shunt Control* (Pwr Bus Ctrl) Boards	1	1	1	30%	1.3
Battery Control Boards	3	0.8	2.4	30%	3.12
Diodes* Boards	1	0.4	0.4	30%	0.52
Shielding	1	1.66	1.66	30%	2.16

Component	Fit Units	CBE/Unit (kg/unit)	CBE (kg)	Cont.	CBE + Cont. (kg)
<b>Propulsion</b>					
Gas Service Valve	4	0.23	0.92	2%	0.94
HP Latch Valve	6	0.35	2.1	2%	2.14
Solenoid Valve	4	0.35	1.4	2%	1.43
HP Transducer	2	0.27	0.54	2%	0.55
Gas Filter	2	0.11	0.22	2%	0.22
Temp. Sensor	4	0.01	0.04	2%	0.04
Liq. Service Valve	2	0.28	0.56	2%	0.57
Test Service Valve	2	0.23	0.46	2%	0.47
LP Transducer	8	0.27	2.16	2%	2.2
Liq. Filter	2	0.72	1.44	2%	1.47
LP Latch Valve	8	0.35	2.8	2%	2.86
Temp. Sensor	20	0.01	0.2	2%	0.2
Lines, Fittings, Misc.	1	3.6	3.6	50%	5.4
DM Monoprop Thrusters 2	16	0.17	2.72	10%	2.99
Biprop Main Engine	4	8.65	34.58	20%	41.5
Fuel Pressurant Tank	1	8.99	8.99	30%	11.68
Ox Pressurant Tank	1	6.52	6.52	30%	8.48
Fuel Tanks	2	18.94	37.88	30%	49.25
Oxidizer Tanks	1	30.39	30.39	30%	39.51
<b>Structures</b>					
Primary Structure	1	145.7	145.7	30%	189.41
Secondary Structure	1	19.1	19.1	30%	24.83
Solar Array Drive Assemblies	1	4.7	4.7	30%	6.11
Solar Array Latch/Release + Booms	1	2.5	2.5	30%	3.25
Antenna Gimbal Assemblies	1	6.7	6.7	30%	8.71
Sample Capture and Transfer (Struc & Mech)	1	67	67	30%	87.1
Aerobraking Panel	1	8.6	8.6	30%	11.18
Balance Mass	1	6.59	6.59	30%	8.57
Cabling Harness	1	32.97	32.97	30%	42.86
Adapter, Spacecraft side	1	22.57	22.57	30%	29.34
<b>Telecomm</b>					
X/X-HGA 1.0m diam Parabolic	1	1.8	1.8	20%	2.16
X-LGA (8dB) Cassini	2	0.2	0.4	20%	0.48
UHF-LGA MSL Helix	1	0.56	0.56	10%	0.62
SDST X-up/X down	2	2.7	5.4	10%	5.94
Electra	2	5.1	10.2	10%	11.22
X-band SSPA, RF=15W*	2	1.5	3	10%	3.3
X-band Diplexer, high isolation	2	0.8	1.6	10%	1.76
Waveguide Transfer Switch (WGTS)	2	0.38	0.76	10%	0.84
Coax Transfer Switch (CXS)	3	0.13	0.39	10%	0.43
Hybrid Coupler	1	0.02	0.02	10%	0.02
X-band Rotary Joint	2	0.25	0.5	10%	0.55
Filter, low power	1	0.2	0.2	20%	0.24
Coax Cable, flex (190)	8	0.16	1.31	25%	1.64
WR-112 WG, rigid (Al)	6	0.43	2.58	25%	3.23
Coax Cable, flex (120)	5	0.09	0.42	25%	0.53

Component	Fit Units	CBE/Unit (kg/unit)	CBE (kg)	Cont.	CBE + Cont. (kg)
<b>Thermal</b>					
Multilayer Insulation (MLI)	32	0.38	12	30%	15.6
General	38.325562	0	0	0%	0
Paints/Films	10	0.09	0.86	30%	1.12
General	1	0.84	0.84	0%	0.84
Isolation (G-10)	200	0	0.86	30%	1.12
Custom	30	0.05	1.5	30%	1.95
Propulsion Tank Heaters	6	0.1	0.6	20%	0.72
Propulsion Line Heaters	20	0.1	2	15%	2.3
Thermistors	60	0.01	0.6	10%	0.66
Mechanical	30	0.05	1.5	30%	1.95
Other Components	6	0	0	0%	0
OS Capture - MLI	10	0.5	5	30%	6.5
OS Capture - Cond Iso	6	0.1	0.6	30%	0.78
OS Capture - Surf	5	0.05	0.25	30%	0.33
OS Capture - Htrs	10	0.02	0.2	30%	0.26
OS Capture - Thermostats	20	0.02	0.3	15%	0.35
OS Capture - Temp Sensors	50	0.02	1	10%	1.1



# Appendix D. Sample Receiving Facility Planning Article

The following article “Planning Considerations for a Mars Sample Receiving Facility: Summary and Interpretation of Three Design Studies” provides a comprehensive overview of the SRF design studies, including cost and background.

Reprinted with permission from Beaty et al., “Planning Considerations for a Mars Sample Receiving Facility: Summary and Interpretation of Three Design Studies,” *Astrobiology* **9**(8): 745–758, 2009, Mary Ann Liebert, Inc., publishers, [www.liebertpub.com/ast](http://www.liebertpub.com/ast).

# Planning Considerations for a Mars Sample Receiving Facility: Summary and Interpretation of Three Design Studies

David W. Beaty,<sup>1</sup> Carlton C. Allen,<sup>2</sup> Deborah S. Bass,<sup>1</sup> Karen L. Buxbaum,<sup>1</sup> James K. Campbell,<sup>1,\*</sup> David J. Lindstrom,<sup>3</sup> Sylvia L. Miller,<sup>1,\*</sup> and Dimitri A. Papanastassiou<sup>4</sup>

## Abstract

It has been widely understood for many years that an essential component of a Mars Sample Return mission is a Sample Receiving Facility (SRF). The purpose of such a facility would be to take delivery of the flight hardware that lands on Earth, open the spacecraft and extract the sample container and samples, and conduct an agreed-upon test protocol, while ensuring strict containment and contamination control of the samples while in the SRF. Any samples that are found to be non-hazardous (or are rendered non-hazardous by sterilization) would then be transferred to long-term curation. Although the general concept of an SRF is relatively straightforward, there has been considerable discussion about implementation planning.

The Mars Exploration Program carried out an analysis of the attributes of an SRF to establish its scope, including minimum size and functionality, budgetary requirements (capital cost, operating costs, cost profile), and development schedule. The approach was to arrange for three independent design studies, each led by an architectural design firm, and compare the results. While there were many design elements in common identified by each study team, there were significant differences in the way human operators were to interact with the systems. In aggregate, the design studies provided insight into the attributes of a future SRF and the complex factors to consider for future programmatic planning. Key Words: Mars—Sample Receiving Facility (SRF)—Mars Sample Return (MSR)—Curation—Biosafety—Test protocol—Sample preservation—Containment—Clean room—NASA—Planetary protection. *Astrobiology* 9, 745–758.

## 1. Introduction

A ROBOTIC MISSION to collect samples of Mars and transport them to Earth has been considered in one form or another for more than three decades (*e.g.*, NRC, 1978, 1990a, 1990b, 1994, 1996, 2002, 2007; MEPAG ND-SAG, 2008, and references therein). Although different variants of this mission over the years have taken different names, we refer to the mission described in this paper as Mars Sample Return, or MSR. In an engineering sense, MSR as a flight mission is one of the most complex undertakings NASA and its European partners have ever considered—there are some fascinating challenges related to the flight system (see, *e.g.*, Bar-Cohen *et al.*, 2005; Gershman *et al.*, 2005; Mattingly *et al.*, 2005; Stephenson and Willenberg, 2006; iMARS, 2008; Moura *et al.*, 2008; Backes *et al.*, 2009). In addition to the complexities of the

flight system, the planning for management of the samples once they arrive on Earth is equally critical. Perhaps the most important single element of the “ground system” is a facility referred to as the Sample Receiving Facility (SRF), whose purpose would be to receive the returned spacecraft, extract the sealed sample container, open it to access the samples, and then carry out a set of tests under strict containment conditions to determine whether the samples are hazardous.

The SRF element of the overall mission is mandatory because of international planetary protection agreements (see, *e.g.*, Atlas, 2008; COSPAR, 2008). The NRC (1997) pointed out that, though the probability of extant martian life in such a returned sample is very low, it is nonzero. Because of this, a sample returned from Mars would be subject to the very rigorous rules and practices in place to protect Earth from the potential risk of extraterrestrial life. The interested reader can

<sup>1</sup>Mars Program Office, and <sup>4</sup>Science Division, Jet Propulsion Laboratory, California Institute of Technology, Pasadena, California.

<sup>2</sup>NASA Johnson Space Center, Houston, Texas.

<sup>3</sup>NASA Headquarters, Washington, DC.

\*Retired, Mars Program Office, Jet Propulsion Laboratory, California Institute of Technology, Pasadena, California.

refer to the specifics of these policies at COSPAR (2008) and MEPAG ND-SAG (2005, 2008). Although the purpose of the policy is clear, there has been considerable debate about the nature of the facility required to implement it.

The purpose of this paper is to summarize a set of studies that were undertaken in 2003 to help constrain the minimum facility for policy compliance, with a specific goal of defining its probable basic attributes and estimating its cost. Although MSR is not currently approved by any of the international space agencies, this information will be needed prior to planning the budget and timeline for the SRF should MSR proceed in the future.

### 1.A. History and context

The first in-depth discussion of facility planning for an MSR-related SRF was carried out in connection with planning for the MSR 2003–2005 Project. The term “Mars Receiving Facility” was introduced at the Mars Sample Handling, Distribution, and Analysis Workshop (D. McCleese and M. Drake, Chairs), which was held at Caltech in February 1999. This facility concept was renamed later that year, however, to the more generic “Sample Receiving Facility” (or SRF) by NASA’s newly formed Mars Returned Sample Handling team because of the possibility that such a facility might be used in the future for samples originating from planetary objects other than Mars.

Reports from studies and workshops during the decade leading up to the 2003–2005 MSR effort established the context for SRF design and implementation. In 1995, NASA asked the National Research Council (NRC) to conduct a study pertaining to sample return and address the key issues<sup>1</sup> associated with the potential risks to Earth of samples returned from Solar System bodies, such as Mars. The NRC panel focused principally on Mars and produced a report (NRC, 1997) that became a cornerstone for much of the planetary protection-related work of the MSR 2003–2005 Project. In addition, the NASA Mars Sample Handling and Requirements Panel (MSHARP) made recommendations (Carr *et al.*, 1999) regarding what is required to certify returned samples as non-hazardous and the considerations associated with sample receiving, curation, and distribution. MSHARP recommended that the samples be treated as hazardous until proven otherwise, consistent with the NRC (1997).

Because the earlier reports provided advice at a fairly general level, the NRC followed up with a study of the criteria for release of samples from biocontainment in an SRF (NRC, 2002). Of relevance to the present study, the report recommended that only the most basic operations should be conducted inside the facility, and it should be designed to the smallest and simplest possible scale consistent with its dual

roles as a biological containment and clean-room facility, with detailed protocols and procedures for handling and testing martian samples. This report additionally argued that it would take at least 7 years in advance of the anticipated return of martian samples to plan and construct an SRF.

Beginning in 1997, NASA sponsored a series of workshops (*e.g.*, DeVincenzi *et al.*, 1999; Race and Rummel, 2000; Race *et al.*, 2001a, 2001b) to prepare a first draft of the test protocol that would evaluate the safety of returned martian samples. The overall objective was “to produce a draft protocol by which returned martian sample materials could be assessed for biological hazards and examined for evidence of life (extant or extinct), while safeguarding the purity of the samples from possible terrestrial contamination.” The resulting Draft Test Protocol (Rummel *et al.*, 2002) was published with the expectation that there would be continued revisions as more information became available about Mars and analytical techniques improved. The Draft Test Protocol is described in greater detail below, because it served as a source of design requirements for the SRF studies summarized here.

NASA’s MSR 2003–2005 Project advanced as far as its Preliminary Design Review before it was cancelled in 2000 (O’Neil and Cazaux, 2000). NASA recognized, however, that if an MSR project were restarted in the future, it must include realistic planning parameters for the SRF, including cost, schedule, and size. Therefore, planning activity for the SRF continued through 2004, several years beyond the cancellation of the flight mission. A major aspect of this planning was a set of three independent competed industry studies that were carried out in 2003–2004. These studies have formed the basis for a much clearer understanding of the possible requirements, design, cost, timeline, and operational considerations for an MSR-related SRF and are the focus of this paper.

## 2. Methods and Conceptual Requirements

No individual facilities currently exist that meet all the requirements of the SRF (which are described in a following section) (see also Atlas, 2008). Moreover, there are technical reasons related to achievement of the necessary standards of cleanliness, which led us to conclude that it was very unlikely to achieve an acceptable SRF by modifying an existing building. Thus, for the purpose of this study, we focused only on the planning of a new facility. This would constitute a reference point to which possible alternative options related to modification of existing facilities could be compared in the future.

In response to a NASA-originated solicitation, seven letters of interest were received in May 2003. Through an evaluation board, three architectural design teams were selected to carry out separate \$200 thousand, 6-month studies. Each team had industry experts who specialize in clean-room design, biohazard considerations, aseptic processing, robotics, and advanced instrumentation. The three teams were led by Industrial Design and Construction (IDC) of Portland, Oregon; Lord, Aeck, Sargent (LAS) of Atlanta, Georgia; Flad & Associates (FLAD) of Madison, Wisconsin. The three industry teams operated independently and delivered their analyses in 2004 in the form of final reports to be used by NASA for future planning.

Each of the architectural design teams was asked to conduct a design study and also provide a cost estimate for an

<sup>1</sup>The NRC (1997) addressed the following issues: (a) the potential and probability for a living entity to be included in a sample returned from another Solar System body, in particular Mars; (b) the scientific investigations that should be conducted to reduce uncertainty in the above assessment; (c) the potential for large-scale effects on the environment resulting from the release of any returned entity; (d) the status of technological measures that could be taken on a mission to prevent the unintended release of a returned sample into Earth’s biosphere; and (e) the criteria for controlled distribution of sample material, taking note of the anticipated regulatory framework.

SRF that operates at a containment level equivalent to Biosafety Level 4 (BSL-4). For the purpose of the analysis, it was assumed that the SRF would receive samples from Mars collected by a mission launched in 2013, with the samples returned to Earth at the end of 2016, by which time the SRF would have been certified to receive samples. The teams were asked to prepare designs that would meet requirements for (a) *ensuring containment* of potential non-terrestrial biological material in the sample, (b) *preventing contamination* of the sample by terrestrial contaminants (biological and inorganic materials), and (c) *permitting preliminary examination, hazard assessment, and life-detection analyses* of the samples.

### 2.A. Draft test protocol

The design teams were told that the SRF concepts must permit implementation of the Draft Test Protocol (Rummel *et al.*, 2002). This document lays out an approach for returned samples to be subsampled and subjected to “sufficient testing to evaluate them against the release criteria.” The Protocol itself has three main segments: physical/chemical processing, life-detection testing, and biohazard testing. In the Protocol, these tests are defined, and flow charts are used to complement the text in describing the conceptual flow through the test process. There is emphasis throughout on approaches to sample examination that are credible, thorough, and informative while maintaining a priority for sample preservation—both in quantity and quality. The developers of the Protocol were careful to point out that the tests must be *sufficient* to answer the key questions concerning possible life and biohazard while preserving, to the greatest extent possible, the quantity of sample available for future science. Therefore, the Draft Test Protocol “attempts a compromise between the desire to destructively analyze only a small proportion of the returned sample by planetary protection testing, and the need to assure safety by testing all portions of all samples.” All the while, the sample portions preserved for science must remain pure (uncontaminated) and unaltered to the greatest extent possible.

### 2.B. Facility scope

For the purpose of the industry studies, long-term, major scientific research in the SRF was not to be considered—either the samples meet the release criteria and are allocated to non-containment laboratories or additional facilities at the SRF must be created. The design teams were told that SRF concepts under consideration should represent the minimum facility to implement the Draft Test Protocol on representative samples within 6–9 months of sample receipt. To comply with the Draft Test Protocol, the teams were to assume the need for testing on live animals (although it was recognized that this need might eventually be eliminated). Further, they were to address whether it would be preferable to include this functionality in the SRF or make use of some secondary facility that meets the SRF containment requirements though not necessarily the sample cleanliness requirements.

The design concepts for the SRF had to provide for the following:

- (1) Receiving and opening the spacecraft, removing the samples;
- (2) Sample splitting and packaging as required to provide subsamples for further testing as specified in the Draft Test Protocol;
- (3) The capability to sterilize subsamples for analysis outside of containment;
- (4) The sterilization of any waste products from the SRF that might have been exposed to martian samples;
- (5) The capability to prepare and package martian samples that have been certified non-hazardous for transfer to a Mars Sample Curation Facility and distribution for further science investigations.

### 2.C. Containment and sample purity

The special considerations of biocontainment, coupled with the limited amount of precious sample and the scientific requirements for sample purity, were fundamental to the industry concept studies. For the purposes of the studies, contamination of returned martian samples fell into three broad categories, based on expected and proposed areas of scientific investigations: biological, organic, and inorganic. In practice, an investigation in one of these areas might not be adversely affected by contamination in a different area. However, the first-order principle was that all three categories must be considered together. A report by Neal (2000) on behalf of the NASA Curation and Analysis Planning Team for Extraterrestrial Materials (CAPTEM) addresses these issues in some detail. CAPTEM’s recommendations, like those of the NRC (2002), recognized a major technical obstacle to designing the SRF: the problem of combining high-level biological containment with clean-room conditions. For example, when considering design of the containment facility for potentially hazardous samples, it is expected that samples would be stored under negative air pressure with respect to the outside laboratory to maximize biocontainment. By contrast, non-hazardous samples that must be kept pristine are typically stored under positive air pressure to minimize contamination. This illustrates the unusual requirement for an SRF to maintain both sample containment and cleanliness.

A significant part of the scientific purpose of MSR would be to evaluate returned martian samples for evidence of martian prebiotic chemistry, martian life itself, or both. Since Earth-sourced contaminants, particularly organic molecules, can give a false-positive signal, contamination control would be an essential aspect of the mission. It would be essential to sterilize and clean all elements that the samples contact between their native state on Mars and their analysis in instruments on Earth. An implication for the SRF is that the interior of the isolator cabinets, the trays, the sample containers, the sample-contact tools, and the sample chambers of the organic detection instruments would need to be cleaned to the same standards as for the sample-contact surfaces of the flight system. The standards and protocols for achieving this would have to be established, but this was not an assumption or SRF requirement for the study teams.

### 2.D. US site selection issues

If it is decided to proceed with selection of a location for an SRF, several issues would need to be addressed. First, one of two general selection processes would have to be chosen:

either an internal down-select process or an external nomination process. The former would entail that a national agency, such as NASA, progressively narrow down on a site that meets its needs; the latter would involve a competition among candidate sites proposed by advocates. Although there are advantages and disadvantages to each approach, it is particularly worth noting that the competitive process would take significantly more time, and this would need to be taken into account in the planning and possibly costing. Second, any pass/fail threshold site criteria would need to be established. These might include perimeter security, government land ownership, access to transportation and utilities, avoidance of legally protected areas, and so on. Third, a set of evaluation criteria would need to be established to determine relative prioritization of candidate sites that pass the threshold criteria. In the US, it is required by the National Environmental Policy Act (NEPA) that the potential environmental impacts be considered early in the decision-making process, but other additional criteria might include fewest land use conflicts, user accessibility and convenience, risk due to natural hazards, and cost (including the cost of mitigating natural hazards). Finally, partnering options (of many different types) might play a significant role in improving the cost, efficiency, or management of the SRF. For example, placing the SRF adjacent to an existing BSL-4 lab might result in certain efficiencies, and this would clearly have site selection implications.

### 2.E. Costing guidelines

To prepare a cost estimate, the teams were given the following additional assumptions:

- (a) The launch of the MSR mission was to occur in November 2013, and the assumed arrival of the sample back on Earth was July 2016.
- (b) Cost estimates for the analytical capabilities, both acquisition and implementation, had to include multi-spectral imaging, microscopy, mass comparison, radiation counting, gas chromatography–mass spectrometry, Raman spectroscopy, X-ray diffraction, X-ray tomography, X-ray fluorescence, atomic force microscopy, and scanning electron microscopy.
- (c) No land-acquisition costs were included. The site for the SRF is treated as a vacant lot in an urban area. That is, roads, power, water and sewer are accessible.
- (d) All tasks associated with NASA personnel were to be budgeted separately.
- (e) All costs related to the external science community were to be budgeted separately.

## 3. Existing Facility Analogues for SRF Functionalities

As discussed above, there is no single facility in the world that would meet all the assumed requirements of the SRF. However, there are separate important facility engineering analogues for most of the aspects of the SRF, and in many respects the essence of the problem is in integrating these different aspects in a way that has never been done before.

### 3.A. Astromaterials Curation Laboratories, Houston, TX

An important model for the facilities issues associated with sample preservation is the Astromaterials Curation

Laboratories at NASA's Johnson Space Center. This complex is organized into a set of curation laboratories within two interconnected buildings. Thus, they share certain facility infrastructure (air, power, water), technical workforce, management, and perimeter security. The different sample collections (lunar rocks and soil, meteorites, cosmic dust, comet dust, solar wind atoms) are curated under different conditions, which are appropriate to the nature of the samples and the nature of the scientific questions these samples are being used to address. These labs are equipped to process, prepare, and distribute samples cleanly to science investigators across the globe.

The curation facility that is most relevant to returned martian samples is the Lunar Sample Laboratory, where the Apollo lunar samples are curated. These samples are stored in positive pressure, high-purity nitrogen gloveboxes within class 1,000 clean rooms. Concentrations of water vapor and oxygen in the gloveboxes are maintained at or below 50 ppm and 20 ppm, respectively. The only materials to come into contact with the samples during processing are Teflon and precision-cleaned stainless steel and aluminum. These materials and procedures were developed to minimize inorganic and particulate contamination of the lunar rocks and soils.

### 3.B. Biosafety Level 4 laboratories

An alternative approach to evaluate requirements and key parameters for SRF planning was to consider analogous aspects of the planning, construction, and certification histories of BSL-4 laboratories (CDC/NIH, 2007; U.S. Department of Health and Human Services, 2007). As of 2004, there were six such labs or lab complexes in North America (Canadian Science Centre, Winnipeg, Canada; Centers for Disease Control and Prevention, Atlanta, Georgia; Georgia State University, Atlanta, Georgia; Southwest Research Institute, San Antonio, Texas; United States Army Medical Research Institute for Infectious Diseases, Ft. Detrick, Frederick, Maryland; and the University of Texas Medical Branch, Galveston, Texas), several of which had either recently been built or had recently added new buildings. Experience with these six facilities showed that the time from planning to certification in 2004 averaged about 8 years, though there was significant dispersion about this mean. However, BSL-4 laboratories do not have a requirement to keep their samples in pristine condition, so the relevance of the BSL-4 analogy was open to questions (Race and Hammond, 2008).

### 3.C. Lunar Receiving Laboratory (LRL)

An important precedent for SRF planning was the development of an analogous facility to support the return of lunar samples by the Apollo Program beginning in 1969. While in containment at the LRL, the samples were evaluated with a test protocol that had been developed in meetings at the Baylor College of Medicine in Houston; hence the name "Baylor Protocol" (Allton *et al.*, 1998). The LRL and the Baylor Protocol were used for the Apollo 11, 12, and 14 missions, after which testing for biological hazards in the lunar samples was deemed unnecessary and was terminated.

There are several significant differences between the LRL and a future SRF. First, the amount of material to be returned by a MSR mission is assumed to be about 0.5 kg (iMARS, 2008; MEPAG ND-SAG, 2008), as compared to hundreds of

kilograms returned by Apollo. Samples from six of the Apollo missions passed through the LRL, but only those from the first three missions did so under biological containment conditions. Second, the LRL was designed to quarantine the astronauts, their capsule, and the lunar rock and regolith samples, whereas the SRF would be designed for sample containment and contamination control only. (Sample containment refers to the protection of humans and the environment from sample hazards, whereas contamination control refers to the protection of sample purity.) Third, the process for securing approvals for construction of facilities has changed significantly. The LRL was completed in five years: initial planning for the LRL began in 1964, construction took place from 1966–1967, operational tests began in 1968, and certification was completed in early 1969 (Mangus and Larsen, 2004). A timeline this rapid is inconceivable today, primarily due to the passage of NEPA, which was signed into law on January 1, 1970. NEPA requires federal agencies to evaluate their proposed projects for potential environmental impacts, and the public must be allowed to comment on the evaluation. Though federal agency evaluations and subsequent public comment are time-consuming endeavors, they are to be considered in assessment of project alternatives prior to NASA taking steps to commit to an irreversible path.

#### 4. SRF Concept Results

The design concepts submitted by the industry teams serve to highlight similarities and differences in how an SRF design might be approached in the future as well as key areas in which technology gaps would need to be filled.

##### 4.A. Primary functional attributes of an SRF

There is a set of attributes that all three SRF concepts have in common. Although the teams made different implementation choices, each design includes the following:

- (1) *Receiving room to handle all Earth-return flight hardware.* The Earth entry flight element of MSR would deliver the martian samples to Earth's surface with the sample canister intact. Regardless of what landing site is selected, the SRF designs assume that terrestrial organisms would contaminate the exterior of the return spacecraft. The SRF would need to be able to receive all the returned flight hardware and have a means by which to extract the samples from within the spacecraft containment systems without incurring contamination by abundant terrestrial life and without alteration of the samples.
- (2) *Secondary containment barrier.* The SRF concepts all would provide a secondary containment barrier equivalent to structures found in BSL-4 laboratory complexes to back up the function of primary containment barriers. Space within this barrier is typically separated from the outside environment by an airlock and a sterilization system such as a chemical shower.
- (3) *Primary containment barrier.* Within the containment facility, there would be isolation cabinets, within which a higher level of cleanliness could be maintained. In each design, these cabinets would provide the primary barrier between the sample and the envi-

ronment, but the implementation details vary considerably (*e.g.*, number, connectivity, approach to sample handling) as described below.

- (4) *Clean spaces for activities involving the pristine samples.* All SRF designs would provide spaces within the primary containment barrier(s) where five different functions could be performed. These spaces would have the common attribute of being as close to pristine as possible to preserve sample purity and assure integrity of sample assessments. The necessary tools and instrumentation would be accommodated, though the approaches do vary. For example, instrumentation might be inside cabinets or on laboratory benches, depending on the specific approach to the containment barriers and sample manipulation. The five main functions would be:
  - (a) *Initial sample characterization*
  - (b) *Pristine sample storage*
  - (c) *Space and tools for subdividing the samples*
  - (d) *Instruments and space needed for life detection*
  - (e) *Instruments and space needed for hazard assessment*
- (5) *Means of moving samples and subsamples between functional elements.* All SRF designs address the need to move samples and subsamples between pristine storage and various test or processing stations while maintaining containment and cleanliness standards. The SRF must also provide systems for detailed record keeping—essentially an early phase of sample curation.
- (6) *Air-handling system.* One of the fundamental principles of biosafety is to have a system of air pressure gradients, so that potentially hazardous samples would be at a low air pressure relative to the human operators and the external environment. If something should leak, air flows toward, rather than away, from the potential hazard. Therefore, a major facility subsystem would be the air-handling capability.
- (7) *Waste sterilization system.* It must be possible to sterilize solid and liquid waste products from the containment lab prior to release into the external environment.
- (8) *Capability to engage observers outside the containment lab both locally and remotely.* There would be intense scientific and public interest in the returned martian samples. Given that the SRF would be engineered for minimal size and cost, only a limited number of people would be able to work in the containment labs. All teams concluded that it would be desirable to provide for an expanded set of people outside the containment barrier who have two-way communication in real time with the scientific and technical staff who are physically carrying out the various tests and other actions within the containment lab. There might be a need to accommodate scientists outside the barrier who would be both local (*i.e.*, at the facility) and remote (*i.e.*, at their home institutions).
- (9) *Office space for permanent staff, including management, research, and administrative.* The SRF would need to provide for sufficient office space for the permanent staff.
- (10) *Office space for guest staff.* Offices and conference rooms would need to be provided for outside researchers. This would be particularly important during the time martian samples are under primary evaluation in the facility.

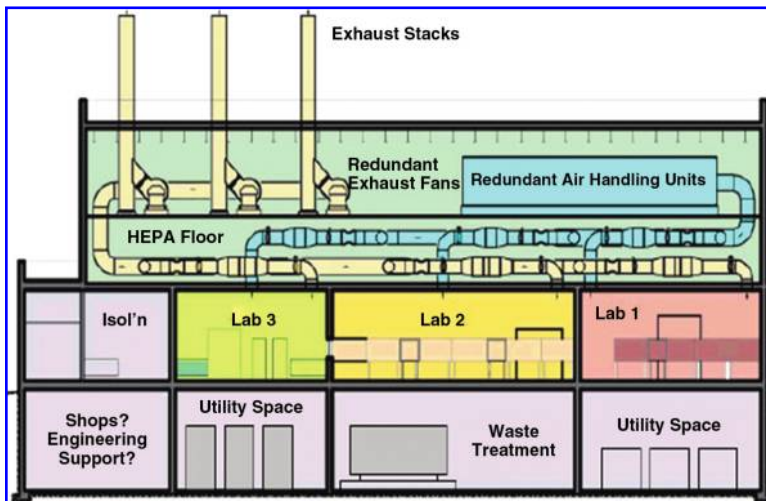

FIG. 1. Sample Receiving Facility cross section (FLAD). Samples would be processed and tested in three separate laboratories. These laboratories would be supported by extensive air filtration and waste-handling equipment, located above and below the laboratories, respectively. Color images available online at [www.liebertonline.com/ast](http://www.liebertonline.com/ast).

- (11) *Laboratory and engineering support facilities.* Several types of facility support functions would need to be addressed, including cleaning and sterilization of equipment, instrumentation support and calibration, and provision of purified water and gases.
- (12) *Facility security system.* When returned, the martian samples would be entities of singularly high value. Physical security to protect against theft, vandalism, and terrorism would be required.
- (13) *Other.* To ensure containment and contamination control, the SRF would require operator safety systems such as fire protection, emergency oxygen supplies, an uninterruptable power supply, and other backup systems. The SRF would need to be operated under controlled conditions, including humidity, temperature, and potentially inert gas. The facility would need the capability to test and monitor all its essential safety systems and their backups. The facility must be able to maintain containment under a variety of off-nominal conditions, including power failure.

#### 4.B. FLAD team concept

The FLAD team developed a preliminary concept of containment and identified the aspects of the preliminary concept that would require additional research before the concept could be developed further. They proposed a design that features three types of containment laboratories, each with unique functions. These laboratories would be located above utility and waste-treatment spaces and below air-handling spaces with roof exhausts. This design is similar to most BSL-4 labs currently operating in the United States (Fig. 1).

Laboratory 1 would be a glovebox<sup>2</sup> facility, designed for manual initial processing of the spacecraft and samples.

<sup>2</sup>Class III Biological Safety Cabinets are sometimes called “gloveboxes.” In this device, the interior of the cabinet is maintained under negative pressure (relative to the room), with HEPA filters attached to the supply and exhaust air systems. Class III BSCs can be connected together so that different activities can be performed sequentially on samples in containment. Autoclaves, incubators, dunk tanks, sample-transfer ports, and animal caging may be connected to the glovebox line.

Laboratory 2 would also be a glovebox facility that would use robots to perform initial sampling, subdivision, and sample testing. Gloves would be used only for maintenance and initial placement of equipment. Gloves would be sealed off during normal operations. Laboratory 3 would be a traditional BSL-4 suit facility, designed for biohazard and life detection, including small animal studies. All laboratories would be supplied with high efficiency particulate air (HEPA) filtered air, and each would have a separate combination of biological containment and air cleanliness appropriate to its operation.

The “gloveboxes” would be linked double-walled Class III Biological Safety Cabinets (BSCs), with reduced pressure between the walls (Fig. 2). This technology is designed to minimize contamination of both the laboratory and the samples in the event of a leak. The double-walled version of these cabinets and their associated gloves are not currently available (they are concept only), and represent significant design and operating challenges. While the single-walled versions are an accepted alternative to suits for BSL-4 operations, the double-wall technology would require detailed study to warrant such acceptance.

The FLAD SRF concept would include robots to perform initial sampling, subdivision, and sample testing. The current generation of industrial robots, particularly those used in microelectronics fabrication, has an impressive record of flexibility, reliability, and cleanliness. However, the capabilities of specific robots in the unique SRF environment must be the subject of extensive development, testing, and verification.

#### 4.C. LAS team concept

The LAS team concept is a fully robotic SRF, with the exception of the *in vivo* biohazard testing. All sample handling, testing, and storage would be carried out inside one interconnected, multi-branching train of Class III BSCs (Fig. 3). The various branches would lead to different clusters. In the central node of each cluster, a robotic arm would perform the operations on the samples with specially designed end effectors, tools, instruments, and equipment. These robotic arms might have 6 degrees of freedom if needed for complex motions, or be a simpler type for moving samples from one station to another.

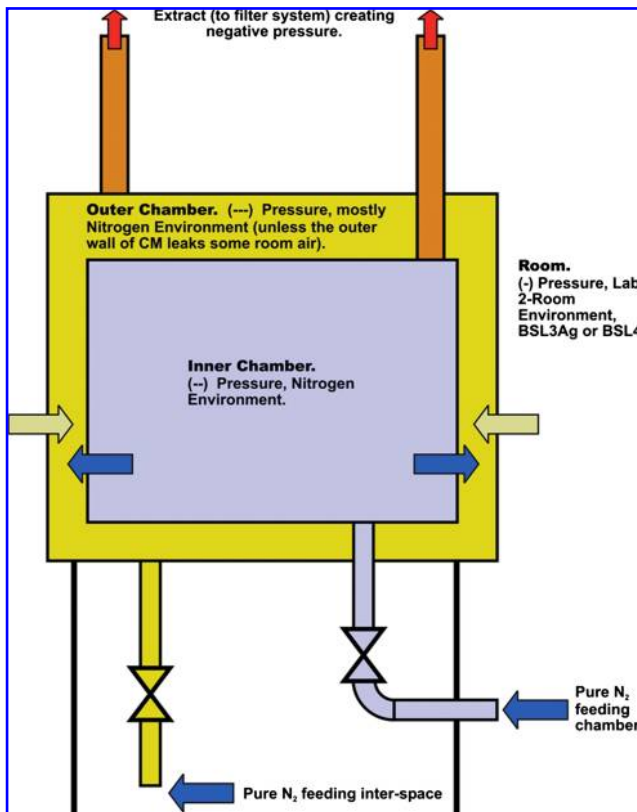

FIG. 2. Double-walled BSC schematic (FLAD). Samples would be stored and tested under nitrogen gas in the inner chamber, which would be held at negative pressure with respect to the surrounding room. Contamination from either the sample or the room would be captured in the outer chamber, which would be held at even lower pressure. Color images available online at [www.liebertonline.com/ast](http://www.liebertonline.com/ast).

A significant driver for the LAS team’s SRF concept is the consideration that, based on past BSL-4 experience, most breaches in containment are related to human error of one type or another and, in particular, issues associated with the

gloves. In addition to susceptibility to needle punctures and other kinds of material failure, there are risks to the samples of imprecise manipulation of very small objects by double-gloved human hands. LAS proposed a design by which robotic manipulators would be employed, to the maximum extent possible, for direct contact with samples. Since multiple activities would need to be performed on the samples, this would require multiple isolator boxes and multiple robotic manipulators. LAS made the case that this approach would be the lowest-risk, both from the point of view of sample contamination and containment assurance, though it would clearly not be the lowest cost.

This concept would require a relatively small primary containment area that would use robotics to minimize human exposure and contamination. Biohazard testing would be carried out in a separate BSL-4 suit laboratory. These laboratories would be located above utility and waste-treatment spaces and below air-handling spaces.

The LAS team concept would use robots in most phases of laboratory operations, including spacecraft dismantling, removal of samples from their containers, initial sample characterization and subdivision, subsample packaging and transport, sample testing and analysis, and storage. Humans would perform hands-on maintenance and repair via gloveports. The capabilities of robots to perform all these tasks under stringent cleanliness and biosafety requirements would require extensive development, testing, and verification.

A unique feature of the LAS approach is the use of “common carriers” to transport and contain subsamples. The use of such devices is standard in the electronics fabrication industry, where conditions of extreme cleanliness are maintained in these “mini-environments” without requiring such stringent cleanliness in the entire laboratory.

The LAS team report also devotes considerable attention to the subjects of decontamination and sterilization. The SRF must have the capability to decontaminate and sterilize the entire laboratory, specific containment vessels, robots, and individual components. Sterilization techniques are well developed in industrial and research laboratories but would

FIG. 3. Fully robotic SRF floor plan (LAS) concept. Samples would be manipulated by robotic arms in an interconnected series of BSCs. Individual samples would be contained and transported in extremely clean “common carriers.” Color images available online at [www.liebertonline.com/ast](http://www.liebertonline.com/ast).

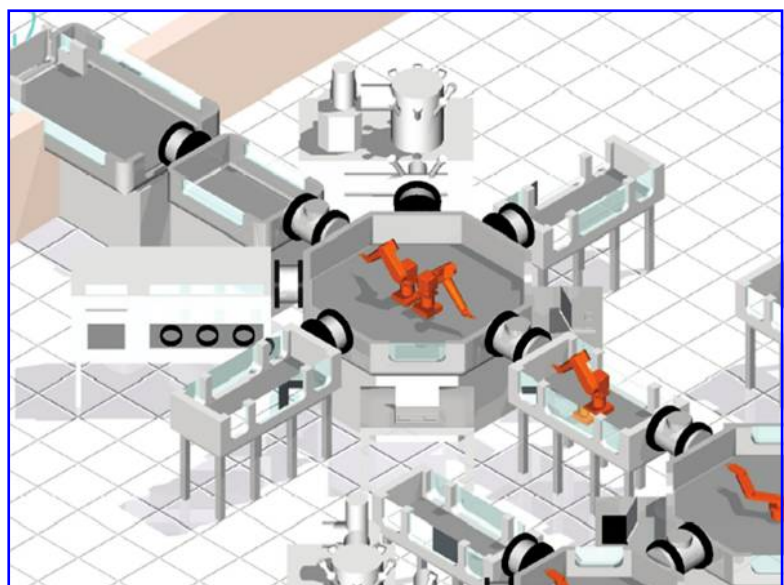



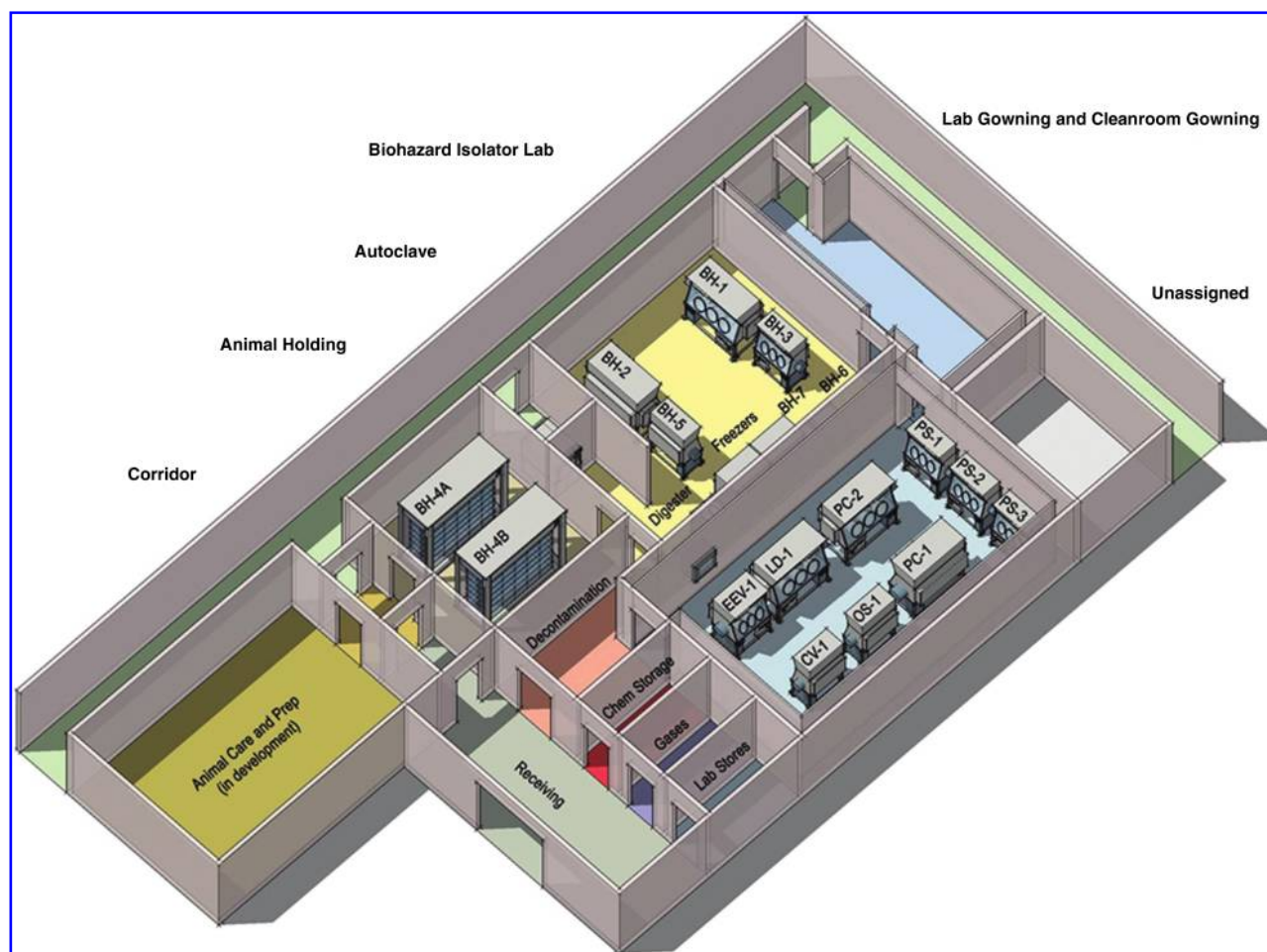

**FIG. 4.** Minimal robotic SRF floor plan (IDC). Samples would be stored and manipulated in individual glovebox isolators. Material would be moved between isolators via rapid-transfer ports. Color images available online at [www.liebertonline.com/ast](http://www.liebertonline.com/ast).

need to be adapted to the unique requirements of the SRF. That is, decontamination techniques (*i.e.*, complete removal of organic and biological materials and contaminants) are not well developed, since, ordinarily, sterilization is deemed sufficient.

#### 4.D. IDC team concept

The IDC team designed an SRF that would make minimal use of robotics technology. Their design features separate clean-room laboratories for physical and chemical testing, life detection, and biohazard testing (Fig. 4). Sample handling, physical and chemical testing, and storage would be conducted in separate, controlled-atmosphere “isolator” gloveboxes.<sup>3</sup> The isolators would be maintained at negative pressure with respect to the laboratory, with HEPA filtered interiors for a Class 10 clean environment to protect the samples. The isolators would be located in BSL-3 level lab rooms that would allow the staff to be dressed in lab garments, rather than positive-pressure personnel suits.

<sup>3</sup>“Isolators” are not necessarily “gloveboxes.” The term “isolator” is generally used to describe a bacteriology incubation device that may have gloves attached.

The isolators would not be interconnected, so each cabinet must be self-sufficient (*i.e.*, with its own airlock, gas supplies, etc.). Samples would be moved between isolators by way of “rapid transfer ports.” These containers would feature a double-door transfer system that would permit docking and undocking from isolators while maintaining biocontainment. Rapid transfer ports were originally developed for the nuclear industry but are now accepted for sample transport in high-level biosafety laboratories.

#### 4.E. Comparison of sample processing approaches

In our comparison of results of the studies, we focus on the key characteristics associated with the sample processing functions, with minor discussion of facility maintenance and support staffing costs. The sample processing functions could be grouped into five steps, as outlined in Table 1, along with a summary of each team’s approach. Any credible approach to each processing step must address both *cleanliness* and *primary containment*.

**Containment approach.** One method of containment common to the three industry studies is the use of Class III BSCs for primary containment in the initial sample processing steps. These cabinets would provide the highest level of

TABLE 1. SRF SAMPLE PROCESSING FUNCTION AND TEAM APPROACHES

Step	Function	FLAD approach	LAS approach	IDC approach
<i>Summary approach to hardware and sample flow</i>				
1	Receive all Earth-return flight hardware and perform initial disassembly	Three-lab design with mixture of robotic and operator manipulation of samples	Robotic-assisted sample processing in containment vessel in line plus BSL-4 <i>in vivo</i> lab for biohazard test	Large clean lab with specialized isolators; mainly operator manipulation of samples
2	Receive sample canister and perform initial disassembly and sample inspection; initiate subsampling and physical testing	Mobile containment module mated to or admitted through airlock to containment module (CM) in Lab 1. Personnel in lab garments would use glove ports and mechanical assists in CM.	Sealed mobile containment module would be moved into CM using robotic manipulation and mechanical assists. Truck dock room provided in design.	Upon arrival, Earth Entry Vehicle placed under industrial hood, cleaned by personnel using glove ports and tools in BSL-3 attire, then moved into isolator in clean lab.
3	Perform chemical and life-detection testing on samples	Sample canister transitions to Lab 2 with higher controls to protect samples. Mainly robotic manipulation in CMs. Samples transferred in common carriers.	Continued work in Lab 2. Robotic manipulation in CMs. Samples transferred in common carriers.	Robotic manipulation in specialized characterization clusters. Samples transferred in common carriers.
4	Perform biohazard tests on samples	Continued work in Lab 2. Robotic manipulation in CMs. Samples transferred in common carriers.	Some continued work in Lab 2. Remaining life-detection and biohazard testing in Lab 3 or alternate facility. Personnel in BSL-4 class suits work with animals, plants, cultures, etc.	Robotic manipulation in specialized characterization clusters. Samples transferred in common carriers.
5	Store samples in pristine environments	Some continued work in Lab 2. Remaining life-detection and biohazard testing in Lab 3 or alternate facility. Personnel in BSL-4 class suits work with animals, plants, cultures, etc.	Samples move through airlock to biocontainment area. Personnel in BSL-4 class suits work with animals, plants, cultures, etc. Use biosafety cabinets and gloveboxes.	Manipulation of samples by personnel in lab garments using glove ports and tools in CM. Class 10 clean room.
		To be worked.	Tested samples retained at each characterization cluster for interim storage. Remaining samples kept in pristine storage.	Manipulation of samples by personnel in lab garments using glove ports and tools in CM. Class 10 clean room.

CM, containment module.

protection of the external environment from the internal contents. They are used in many industrial and biological research labs to provide the primary containment. They are of gas-tight construction but ventilated to provide critical environmental control, with both incoming and outgoing HEPA filtration.

The three industry study concepts also use other critical containment methods common in BSL-4 laboratories and facilities. They include careful designs of the lab space sur-

rounding the BSCs, special waste treatment, air handling and utility systems, as well as safety and security provisions.

**Cleanliness.** All study concepts make use of many important cleanliness methods. For example, all three concepts propose the use of double-walled BSCs that, in addition to containment, would provide some protection for the samples. Also, in the initial process of dismantling the Earth-return vehicle, all three concepts would clean and sterilize

the outside of each spacecraft element and transfer the cleaned element(s) into the next pristine BSC.

**Disparate sample sizes.** All three concepts share some essential characteristics, such as their capability to deal with all forms of material likely to be contained in the returned sample. For example, all three SRF concepts plan to use appropriate forms of containers and tools/end effectors for gas, fines (<1 mm), coarse material (>1 mm), and “large rocks.” The designs presented in the three study concepts also share the capability to capture the martian atmospheric gases, separate dust from this sample, and package each for testing and storage. They also have in common the notional capability to perform physical, chemical, life-detection, and biohazard testing on a portion of each solid sample.

The differences in the designs originate primarily from different ways to approach three issues:

- (1) *Approach to maintaining sample purity.* The strategy of MSR would include bringing samples that might contain little or no evidence of life into an environment (an Earth laboratory) where sources of life-related contamination are essentially everywhere. Getting a laboratory “blank” down to as low a level as possible would likely take heroic efforts. Since human beings are a major potential source of biological contamination, it is important to carefully consider the proximity of humans to the martian samples.
- (2) *Approach to containment assurance.* While the notion that any returned martian samples must be kept isolated is not unique, reduction of terrestrial contamination to an acceptable risk threshold could be established in a number of different ways.
- (3) *The relationship of instrumentation to the containment system.* Would all the instruments required to carry out the purpose of the SRF need to be placed inside the isolator cabinets (the primary containment system), or could some of them be operated in an open laboratory? Some of the instruments that would be required by the test protocol might include relatively sophisticated devices, such as scanning electron microscopes or mass spectrometers.

**4.F. Building size, cost, and schedule**

At the heart of the motivation to conduct the SRF concept studies was the need to gain a better understanding of parameters relevant to program planning—facility scope or size, cost, and timing. The reports that were delivered, combined with some interpretation to enable direct comparison, provided insights in each key area.

- (1) *Building size.* A key objective of this study was to estimate the minimum building size that would be sufficient to carry out the SRF function. The overall facility size estimated by three independent groups ranged from about 35,000 to 60,000 square feet. This floor space could be broken down as follows:
  - (a) 25,000–40,000 square feet of space related to the containment labs that constitute the facility core. This would include not just the contained laboratory rooms (which are estimated to be about 5,000–

10,000 square feet, depending on the implementation concept) but also the gowning area(s), decontamination showers, waste storage and treatment, interstitial space, clean sample storage, airshafts, and the perimeter corridor. The sample receiving requirements imply a receiving dock connected to a decontamination laboratory, which would need to be part of the containment core of the laboratory (one of its functions would be to test the spacecraft seals)—its space needs are estimated to be about 1,000 square feet for the decontamination lab and an additional 1–2 times that for the uncontained receiving dock and an associated support lab.

- (b) 10,000–15,000 square feet of office, administrative, and logistical support space (including storage, security).
  - (c) ~5,000 square feet of high-containment lab-support space (including testing shops).
- (2) *Cost.* Each of the three design teams estimated the cost and cost profile based on the SRF scenario that was presented to them and their interpretation of how to best implement it. At the end of the industry studies, the Mars Program study lead normalized the three different team estimates to place them on as comparable a footing as possible, and a composite budget profile was prepared (Table 2). The annual budgets in the composite are expressed in units of dollars for each respective fiscal year (so-called “real year” dollars), with an overall total of \$121 million. The permanent staff necessary to operate the SRF is estimated to be about 20–30 persons, for an annual operational cost of \$7 million. This estimate includes single-shift administrative, facility support and maintenance, and core

TABLE 2. ESTIMATED COST TO DESIGN, BUILD, AND OPERATE AN SRF

Assume MSR launches in 2013, samples arrive on Earth in 2016

	Annual budget (millions, real-year dollars)	Life-cycle phase
FY05	0.2	Oversight of advanced technology development, site selection
FY06	0.6	Design
FY07	1	
FY08	2	
FY09	3	
FY10	10	Construction
FY11	26	
FY12	23	
FY13	22	Commissioning Training, operational readiness testing
FY14	7	
FY15	7	Samples arrive, are active within facility
FY16	7	
FY17	7	
FY18	5	
<b>Total</b>	<b>121</b>	

FY, fiscal year.

building operations staff. These figures do not include the large number of personnel that would be required to carry out the work of the Test Protocol, such as guest scientists, planetary protection officials, and planetary program managers during the years of active sample handling and study within the SRF. Additionally, we caution that this cost estimate also does not include the research and technology development efforts necessary to provide key functionality in the SRF. Although this cost profile and total cost is specific to the study scenario, it might be adjusted to alternate future scenarios by applying the appropriate inflation factors. To make such a cost adjustment to alternative or future scenarios, it is crucial to refer to the key underlying assumptions concerning schedule and cost basis that were presented earlier in Section 3E.

- (3) *Schedule.* The three teams each analyzed the schedule that would be needed to acquire permits, conduct design, construct the facility, and commission the SRF they envisioned. The estimated total schedule duration from the start of concept design and site selection activities to readiness to receive samples is approximately 7 years. Note that this estimate does not include the significant research and development effort required to reach the ready-to-build stage. Additionally, this schedule is estimated to vary by 1 to 2 years, primarily depending on whether NASA used an internal or external site selection process (an internal site selection process would mean that only properties under the jurisdiction of the Federal Government are considered, whereas external site selection would mean that private landowners, state governments, and institutions could also propose facility locations). The schedule would have to be lengthened by approximately 2 years should an external property purchase be required. For comparison, Rummel *et al.* (2002) and Atlas (2008) estimated that this amount of work would take 9 years and 10 years, respectively. An obvious difference is that these industry study teams were accustomed to designing and constructing buildings in an environment where things move more quickly than might be true of this unique SRF project.

#### 4.G. Areas for further analysis and technology development

Analysis of the SRF design trade space has identified several major recognizable technology gaps [see also the planning reported by Mattingly *et al.* (2005), which was based on the same SRF studies reported in this paper] and some areas requiring further analysis.

*Decontamination techniques.* Methods for removing organic, inorganic, and particulate contamination from containers, BSCs, robotic manipulators, and hand tools coming into contact with the samples or their environment.

*Double-walled glovebox containment.* Design, fabrication, testing, and certification of a biosafety cabinet with a double wall enclosing a low-pressure space, designed to trap leakage from the samples as well as contaminants from the outside laboratory.

*Robotics.* Demonstrate operations of dexterous ultra-clean robots capable of sample transport and sample manipulation

(see also Mani *et al.*, 2008). As pointed out by Bell and Allen (2005), a key issue is whether the robotics can be made compatible with the cleanliness requirements.

*Pristine sample preservation.* Methods of preserving martian rock, soil, and atmosphere samples for long-term storage and distribution to researchers in a wide variety of disciplines.

*Scientific equipment required for proper sample analysis.* Specific instruments to conduct the testing required for assessment of possible life and biohazards in martian rock, soil, and atmosphere samples.

## 5. Discussion and Future Planning

Three independent industry studies produced complementary high-level concepts for an SRF dedicated to an MSR mission. These industry study concepts represent a “snapshot in time” relative to our understanding of the characteristics of martian samples, the nature of a sample return mission, the requirements of planetary protection, and the role of international collaboration and regulations in the mission. These detailed studies will need to be redone at some point in the future in light of our updated knowledge of Mars, an updated Test Protocol (note the emphasis on this in Atlas, 2008), the possible internationalization of MSR (*e.g.*, iMARS, 2008; Mani *et al.*, 2008), and our evolving budgetary and political realities.

### 5.A. Some considerations affecting SRF size and cost

The cost presented above is based on a specific scenario, with a circumscribed set of assumptions and requirements. However, the size and cost of the SRF is sensitive to the several possible changes in the assumptions and requirements, some of which might have significant effect on its cost.

*Partnering options.* The SRF scenario evaluated in this study was assumed to be a single, new, stand-alone building. Locating this building as part of a campus of other buildings could enable the sharing or avoidance of certain costs, such as perimeter security, access to transportation and utilities, access to a trained technician pool, avoidance of legally protected areas, and so forth. Although the general potential for cost saving is obvious, this cannot be evaluated in detail without specific designs.

*Making use of existing construction.* A single, new, stand-alone building is the simplest (and perhaps the only) way to meet the expected cleanliness requirements. However, it may be possible to configure the SRF as a newly constructed wing of an existing building, or perhaps even as a retrofit of an existing building.

*Live animal testing.* Because the present Draft Test Protocol (Rummel *et al.* 2002) calls for conventional whole-organism animal and plant *in vivo* testing, a significant part of the floor space of the containment laboratory core in the three scenarios relates to animal holding and evaluation areas. Since the Draft Test Protocol was published in 2002 and used as a key element of the baseline requirements for the 2004 industry study concepts, the fields of microbiology and biohazard detection have advanced markedly. The limits of detection and classification of microbial life in

environmental samples have improved significantly, and the use of animals in biohazard testing has been increasingly replaced by cellular and molecular analyses. If a future version of the test protocol eliminates this requirement in accordance with state-of-the-art practices and refinements at the time the final protocol is implemented, the SRF design would potentially be simpler.

**More than one SRF.** The study teams each analyzed the design, construction, and operation of a single SRF. However, in the future it might be possible or required that there are two or more SRFs in different locations, possibly in different countries. If there are multiple SRFs, they could conceivably either be designed with identical capabilities or, alternatively, with the capability to perform different, complementary tests. The possibility of a two-SRF scenario has been discussed both within the 2003–2005 MSR Project and by iMARS (2008) as a potentially desirable, or perhaps even politically necessary, attribute of an international MSR mission. A specific variation on the single-SRF approach (alluded to by Rummel *et al* 2002 in the Draft Test Protocol) is the possibility that live animal testing could be done in a secondary facility that meets the biocontainment requirements of the SRF, which would thus simplify the design and cost of the primary facility. A prerequisite for any two-SRF scenario would be a means by which to move unsterilized samples between facilities and the approval to do so.

**SRF expandability.** This study evaluated the minimum possible SRF that would be required to execute the test protocol. If the samples are determined to be non-hazardous (or are rendered non-hazardous by sterilization), they would be made available for allocation to the world's research community. However, if signs of life are detected in one or more samples, it might become necessary for future study of the returned samples to take place in ongoing containment. The samples would then need to be evaluated with additional methods beyond those used in the Draft Test Protocol. The SRF may need to be designed so that it could be expanded to accommodate additional laboratories; if this functional requirement were accepted, it could have significant cost implications.

## 6. Conclusions

Based on the analysis and interpretation of the 2004 industry study concepts, we suggest the following considerations for planning an SRF to meet the needs of a future MSR mission.

- (1) *Design.* There is more than one possible design for a stand-alone SRF that would meet the requirements of MSR. Because the full set of requirements is not defined at this time, it is not possible to optimize the design. However, it is possible to understand the likely possibilities enough to generate first-order budgeting/planning parameters.
- (2) *Size.* A minimal stand-alone SRF is estimated to have an overall size of about 35,000–60,000 square feet, including 25,000–40,000 square feet of containment-related space that makes up the facility core (of which 5,000–10,000 square feet are the high-containment laboratory rooms; the remainder would consist of

facility support systems including air handling, chemical showers, waste cookers, etc.), up to 5,000 square feet of high-containment lab support space (test and repair shops), and 10,000–15,000 square feet of office, administrative, and logistical support space (including storage and security).

- (3) *Schedule.* The schedule needed to construct and commission an SRF is estimated to be 7–9 years. Most of this variance relates to whether NASA uses an internal or an external site selection process. Because of the schedule-constrained nature of an MSR (*i.e.*, once the samples have left Mars, spacecraft trajectories have a defined schedule that cannot be easily slipped), it is prudent to add additional schedule reserves, and a good planning number is 10 years.
- (4) *Capital cost.* The cost of an SRF would depend upon the specific design approach, as well as on the final test protocol executed in the facility. However, for future planning a reasonable budget estimate is the escalated equivalent of \$120 million real-year dollars, using the 2013 MSR scenario described in Table 2.
- (5) *Operating cost.* During the years the martian samples would be evaluated in the facility, the annual building operating budget would be estimated at \$7 million, which includes a building operations staff of 20–30 persons. This estimate does not include the large number of personnel that would be required to carry out the work of the Test Protocol.
- (6) *Advance technology development.* Most of the technology needed to design and construct an SRF already exists in the biosafety, pharmaceutical, and sample curation communities. However, along with decontamination techniques, double-walled glovebox containment, dexterous ultra-clean robotics, pristine sample preservation, and scientific equipment required for proper sample analysis, some aspects of the project will need to be planned at two specific points in the building life cycle: (a) those that affect the facility design and will need to be known before facility construction, (b) those that affect the instrumentation, the experiments, or both, that will need to be known before the facility is equipped.
- (7) *Partnering opportunities.* Although not fully analyzed in the industry study concepts, it is likely that partnering opportunities might result in cost savings, operational efficiency, or other benefits. Such opportunities could be evaluated against the reference planning parameters described above to determine whether this would be a better way to meet the needs of an MSR than with a stand-alone SRF.

## 7. Acknowledgments

The authors wish to recognize the teams and dedicated individuals at Industrial Design and Construction (IDC) of Portland, Oregon; Lord, Aeck, Sargent (LAS) of Atlanta, Georgia; and Flad & Associates (FLAD) of Madison, Wisconsin, for their diligence, interest, and hard work that comprises the core of this paper. We also want to acknowledge study participant and reviewer Jonathan Richmond, and members of the 1999–2002 Mars Returned Sample Handling team Lisa Fletcher, Mary Sue Bell, Judy Allton,

Stan Farkas, Geoff Briggs, Laurie Carrillo, Kimberly Cyr, Sandy Dawson, Janis Graham, Ragnhold Landheim, Rocco Mancinelli, Ed Mickelson, and Nancy Robertson, whose work led up to the SRF design studies. Thanks also to Margaret Race, John Rummel, and Joe Parrish who all contributed to our understanding during the planning and performance of the SRF design study effort; Jeff Schanz, who provided continued technical assistance after the delivery of the studies; and reviewer Richard Mattingly. The research described in this paper carried out at the Jet Propulsion Laboratory, California Institute of Technology, was done so under a contract with the National Aeronautics and Space Administration.

## 8. Author Disclosure Statement

No competing financial interests exist. The cost information contained in this document is of a budgetary and planning nature and is intended for informational purposes only. It does not constitute a commitment on the part of JPL and/or Caltech.

## 9. Abbreviations

BSC, Biosafety Cabinet or Biological Safety Cabinet; BSL, Biosafety Level; CAPTEM, Curation and Analysis Planning Team for Extraterrestrial Materials; FLAD, Flad & Associates; HEPA, high efficiency particulate air; IDC, Industrial Design and Construction; LAS, Lord, Aeck, Sargent; LRL, Lunar Receiving Laboratory; MSHARP, Mars Sample Handling and Requirements Panel; MSR, Mars Sample Return; NEPA, the National Environmental Policy Act; NRC, National Research Council; SRF, Sample Receiving Facility.

## 10. References

- Allton, J.H., Bagby, J.R., and Stabekis, P.D. (1998) Lessons learned during Apollo lunar sample quarantine and sample curation. *Adv. Space Res.* 22:373–382.
- Atlas, R. (2008) Mars Sample Return Receiving Facility. Presentation to the Planetary Science Subcommittee. Available online at <http://www.lpi.usra.edu/pss/presentations/200803/04-Atlas-PPSonMSR.pdf>.
- Backes, P., Onstott, T., Bar-Cohen, Y., Badescu, M., Pratt, L., Helmick, D., Sherrit, S., Johnson, A., and Bao, X. (2009) Planetary sample sealing for caching. In *Proceedings of the 2009 IEEE Aerospace Conference*, Institute of Electrical and Electronics Engineers, Piscataway, NJ.
- Bar-Cohen, Y., Wu, J., Bley, S., Olorunsola, A.K., Rivellini, T.P., Wincentsen, J., and Gershman, R. (2005) Simultaneous separation, seaming and sealing using brazing (S3B) for sample containerization and planetary protection [Paper #5762-43]. In *Proceeding of the Industrial and Commercial Applications of Smart Structures Technologies*, SPIE Smart Structures and Materials Symposium, The International Society for Optical Engineering, Bellingham, WA.
- Bell, M.S. and Allen, C. (2005) Cleanroom robotics—appropriate technology for a sample receiving facility [abstract 1395]. In *36<sup>th</sup> Lunar and Planetary Science Conference*, Lunar and Planetary Institute, Houston. Available online at <http://www.lpi.usra.edu/meetings/lpsc2005/pdf/1395.pdf>.
- Carr, M.H., editor. (1999) *Mars Sample Handling and Requirements Panel (MSHARP) Final Report* [NASA TM-1999-209145], NASA Jet Propulsion Lab, Pasadena, California.
- CDC/NIH. (2007) *Biosafety in Microbiological and Biomedical Laboratories (BMBL)*, 5<sup>th</sup> ed., U.S. Department of Health and Human Services Centers for Disease Control and Prevention and National Institutes of Health, Washington, DC. Available online at <http://www.cdc.gov/od/ohs/biosfty/bmb15/bmb15toc.htm>.
- COSPAR (2008) *COSPAR Planetary Protection Policy*, Committee on Space Research of the International Council for Science, Paris. Available online at: [http://cosparhq.cnes.fr/Scistr/PPPPolicy\(20-July-08\).pdf](http://cosparhq.cnes.fr/Scistr/PPPPolicy(20-July-08).pdf).
- DeVincenzi, D.L., Bagby, J., Race, M., and Rummel, J.D., editors. (1999) *Mars Sample Quarantine Protocol Workshop* [NASA CP-1999-208772], NASA Ames Research Center, Moffett Field, California.
- Gershman, R., Adams, M., Dillman, R., and Fragola, J. (2005) Planetary protection technology for Mars Sample Return [Paper #2.1607]. In *Proceedings of the 2005 IEEE Aerospace Conference*, Institute of Electrical and Electronics Engineers, Piscataway, NJ.
- iMARS. (2008) *Preliminary Planning for an International Mars Sample Return Mission: Report of the International Mars Architecture for the Return of Samples (iMARS) Working Group*, International Mars Architecture for the Return of Samples Working Group. Available online at [http://mepag.jpl.nasa.gov/reports/iMARS\\_FinalReport.pdf](http://mepag.jpl.nasa.gov/reports/iMARS_FinalReport.pdf).
- Mangus, S. and Larsen, W. (2004) *Lunar Receiving Laboratory Project History* [NASA/CR-2004-208-938], NASA, Washington DC. Available online at [http://ston.jsc.nasa.gov/collections/TRS/\\_techrep/CR-2004-208938.pdf](http://ston.jsc.nasa.gov/collections/TRS/_techrep/CR-2004-208938.pdf).
- Mani, P., Nelson, B., Pauli, U., Kray, R., Huntley, P., Ross, F., Heuer, M., and Hofmann, B.A. (2008) Preliminary concept for a Mars Sample Receiving Facility [abstract # PPP2-0006-08]. In *COSPAR 2008*, Committee on Space Research of the International Council for Science, Paris. Available online at <http://www.cospar-assembly.org/abstractcd/COSPAR-08/abstracts/data/pdf/abstracts/PPP2-0006-08.pdf>.
- Mattingly, R., Hayati, S., and Udomkesmalee, G. (2005) Technology development plans for the Mars Sample Return mission [Paper #151]. In *Proceedings of the 2005 IEEE Aerospace Conference*, Institute of Electrical and Electronics Engineers, Piscataway, NJ.
- Moura, D., Jordan, F., Pradier, A., May, L., Santovincenzo, A., Mattingly, R., Kerridge, S., Khan, M., Gardini, B., and McCuiston, D. (2008) The road to an international architecture for Mars Sample Return: The iMARS Team view [IAC-08-A3.1.3]. In *The 59<sup>th</sup> International Astronautical Congress*, International Astronautical Federation, Paris.
- MEPAG ND-SAG. (2008) Science priorities for Mars Sample Return. *Astrobiology* 8:489–535. Available online at <http://mepag.jpl.nasa.gov/reports/index.html>.
- NRC. (1978) *Strategy for the Exploration of the Inner Planets: 1977–1987*, National Academy Press, Washington DC.
- NRC. (1990a) *Update to Strategy for Exploration of the Inner Planets*, National Academy Press, Washington DC.
- NRC. (1990b) *International Cooperation for Mars Exploration and Sample Return*, National Academy Press, Washington DC.
- NRC. (1994) *An Integrated Strategy for the Planetary Sciences: 1995–2010*, National Academy Press, Washington DC.
- NRC. (1996) *Review of NASA's Planned Mars Program*, National Academy Press, Washington DC.
- NRC. (1997) *Mars Sample Return Issues and Recommendations, Task Group on Issues in Sample Return*, Space Studies Board, Commission on Physical Sciences, Mathematics, and Applications, National Research Council, National Academy Press, Washington DC.

- NRC. (2002) *The Quarantine and Certification of Martian Samples*, National Academy Press, Washington DC.
- NRC. (2007) *An Astrobiology Strategy for the Exploration of Mars*, The National Academies Press, Washington DC.
- Neal, C.R. (2000) Issues involved in a martian sample return: integrity preservation and the Curation and Analysis Planning Team for Extraterrestrial Materials (CAPTEM) position. *J. Geophys. Res.* 105:22487–22506.
- O'Neil, W.J. and Cazaux, C. (2000) The Mars Sample Return project. *Acta Astronaut.* 47:453–465.
- Race, M.S. and Hammond, E. (2008) An evaluation of the role and effectiveness of institutional biosafety committees in providing oversight and security at biocontainment laboratories. *Biosecurity and Bioterrorism: Biodefense Strategy, Practice and Science* 6:19–35.
- Race, M.S. and Rummel, J.D., editors. (2000) *Mars Sample Handling Protocol Workshop Series. Interim Report of the Workshop Series: Workshop 1 Proceedings and Final Report* [NASA/CP-2000-209624], NASA, Washington DC.
- Race, M.S., Kovacs, G.T.A., Rummel, J.D., and Acevedo, S.E., editors. (2001a) *Mars Sample Handling Protocol Workshop Series. Interim Report of the Workshop Series: Workshop 2 Proceedings and Final Report* [NASA/CP 2001-210923], NASA, Washington DC.
- Race, M.S., Nealson, K., Rummel, J.D., and Acevedo, S.E., editors. (2001b) *Mars Sample Handling Protocol Workshop Series. Interim Report of the Workshop Series: Workshop 3 Proceedings and Final Report* [NASA/CP-2001-211388], NASA, Washington DC.
- Rummel, J.D., Race, M.S., DeVincenzi, D.L., Schad, P.J., Stabekis, P.D., Viso, M., and Acevedo, S.E., editors. (2002) *A Draft Test Protocol for Detecting Possible Biohazards in Martian Samples Returned to Earth* [NASA/CP-20-02-211842], NASA Ames Research Center, Moffett Field, CA.
- Stephenson, D.D. and Willenberg, H.J. (2006) Mars ascent vehicle key elements of a Mars Sample Return mission. In *2006 IEEE Aerospace Conference*, Institute of Electrical and Electronics Engineers, Piscataway, NJ.
- U.S. Department of Health and Human Services (2007) *Biosafety in Microbiological and Biomedical Laboratories*, 5<sup>th</sup> ed., US Government Printing Office, Washington DC. Available online at <http://www.cdc.gov/od/ohs/biosfty/bmb15/bmb15toc.htm>.

Address correspondence to:

Deborah S. Bass  
Mars Program Office  
Jet Propulsion Laboratory  
California Institute of Technology  
4800 Oak Grove Drive  
Pasadena, CA 91109-8099

E-mail: Deborah.Bass@jpl.nasa.gov